

INSTALLATION INSTRUCTIONS

AIR HANDLERS

FEATURING INDUSTRY STANDARD R-410A REFRIGERANT 

(-)H2VZ High Efficiency 2-Stage

(-)H3VZ High Efficiency 3+Stages

(-)HMVZ High Efficiency Variable Speed

All Models Equipped with Constant-CFM motors and Rheem EcoNet™ Communications



RECOGNIZE THIS SYMBOL AS AN INDICATION OF IMPORTANT SAFETY INFORMATION!

WARNING

These instructions are intended as an aid to qualified licensed service personnel for proper installation, adjustment and operation of this unit. Read these instructions thoroughly before attempting installation or operation. Failure to follow these instructions may result in improper installation, adjustment, service or maintenance possibly resulting in fire, electrical shock, property damage, personal injury or death.



ISO 9001:2015

DO NOT DESTROY THIS MANUAL

PLEASE READ CAREFULLY AND KEEP IN A SAFE PLACE FOR FUTURE REFERENCE BY A SERVICEMAN

TABLE OF CONTENTS

1.0 SAFETY INFORMATION	4
2.0 GENERAL INFORMATION	6
2.1 IMPORTANT INFORMATION ABOUT EFFICIENCY & INDOOR AIR QUALITY	6
2.2 CHECKING PRODUCT RECEIVED	7
2.3 MODEL NUMBER NOMENCLATURE.....	7
2.4 AVAILABLE MODELS.....	8
2.5 DIMENSIONS & WEIGHTS	9
2.6 IMPORTANCE OF PROPER INDOOR/OUTDOOR MATCH-UPS.....	10
2.7 IMPORTANCE OF QUALITY INSTALLATION	10
3.0 INSTALLATION	10
3.1 TOOLS & REFRIGERANT	10
3.1.1 TOOLS REQUIRED FOR INSTALLING AND SERVICING R-410A MODELS.....	10
3.1.2 SPECIFICATIONS OF R-410A.....	11
3.1.3 QUICK-REFERENCE GUIDE FOR R-410A	11
3.2 APPLICATIONS AND ORIENTATION.....	11
3.2.1 VERTICAL UPFLOW & HORIZONTAL LEFT DISCHARGE	11
3.2.2 VERTICAL DOWNFLOW & HORIZONTAL RIGHT DISCHARGE.....	11
3.2.3 INSTALLATION IN AN UNCONDITIONED SPACE	13
3.2.4 INSTALLATION IN MOBILE/MANUFACTURED HOMES	14
3.2.5 INSTALLATION IN CORROSIVE ENVIRONMENTS	15
3.2.6 SUPPORTING AIR-HANDLER IN HORIZONTAL APPLICATIONS	15
3.3 AUXILIARY OVERFLOW PAN	16
3.4 CLEARANCES.....	16
3.5 DUCT FLANGES	16
3.6 DUCTWORK.....	17
3.7 RETURN AIR FILTER.....	17
3.8 REFRIGERANT LINE CONNECTIONS & CHARGING	18
3.8.1 PREPARATION	18
3.8.2 LIQUID LINE FILTER DRIER.....	18
3.8.3 BRAZING	18
3.8.4 LEAK TESTING	19
3.8.5 EVACUATION.....	19
3.8.6 REFRIGERANT CHARGING.....	19
3.9 EXV VAPOR LINE THERMISTOR/TXV SENSING BULB ATTACHMENT	19
3.10 CONDENSATE DRAIN	21
3.11 ECONET™ CONTROL CENTER OR THERMOSTAT	22
3.12 ELECTRICAL WIRING.....	22
3.12.1 CONFIGURING UNIT FOR 208 VOLT POWER.....	23
3.12.2 GROUNDING.....	23
3.12.3 POWER WIRING	23
3.12.4 COPPER WIRE SIZE - AWG. (3% VOLTAGE DROP).....	23
3.12.5 ELECTRICAL DATA - BLOWER MOTOR ONLY - WITHOUT ELECTRIC HEAT: (-)H2VZ/(-)H3VZ/(-)HMVZ ..	24
3.12.5.1 ELECTRICAL DATA - WITH ELECTRIC HEAT: (-)H2VZ.....	24
3.12.5.2 ELECTRICAL DATA - WITH ELECTRIC HEAT: (-)H3VZ.....	32
3.12.5.3 ELECTRICAL DATA - WITH ELECTRIC HEAT: (-)HMVZ.....	35
3.12.6 ELECTRIC HEATER KIT SUPPLEMENTAL INFORMATION	38
3.12.7 ECONET™ COMMUNICATIONS CONTROL WIRING.....	39
3.12.8 AUXILIARY SWITCH INPUTS.....	39
3.12.9 CONVENTIONAL 24VAC THERMOSTAT CONTROL WIRING.....	40
3.12.10 CONVENTIONAL 24VAC THERMOSTAT CONTROL WIRING CONNECTION DIAGRAMS	41
3.13 AIR-FLOW.....	43
3.13.1 (-)H2VZ/(-)H3VZ/(-)HMVZ AIR-FLOW SETTINGS OVERVIEW	43
3.13.2 (-)H2VZ/(-)H3VZ/(-)HMVZ COOLING & HEAT PUMP HEATING AIR-FLOW SETTINGS	44
3.13.3 (-)H2VZ/(-)H3VZ/(-)HMVZ ELECTRIC HEAT AIR-FLOW SETTINGS	45
3.13.4 (-)H2VZ/(-)H3VZ/(-)HMVZ COOLING MODE DEHUMIDIFICATION.....	45

TABLE OF CONTENTS (continued)

4.0 START-UP	46
4.1 PRE-START CHECKLIST	46
4.2 SYSTEM START-UP AND OPERATIONAL CHECK-OUT	46
4.3 SEQUENCE OF OPERATION	46
4.3.1 COOLING MODE: (-)H2VZ/(-)H3VZ	46
4.3.1.1 COOLING MODE: (-)H2VZ WITH 24VAC SINGLE-STAGE THERMOSTAT	46
4.3.1.2 COOLING MODE: (-)H2VZ WITH 24VAC TWO-STAGE THERMOSTAT	47
4.3.1.3 COOLING MODE: (-)H3VZ WITH 24VAC TWO-STAGE THERMOSTAT	47
4.3.2 COOLING MODE: (-)HMOVZ	47
4.3.2.1 (-)HMOVZ WITH 24 VAC SINGLE-STAGE THERMOSTAT (EMERGENCY MODE)	47
4.3.3 ELECTRIC HEAT MODE: (-)H2VZ/(-)H3VZ/(-)HMOVZ	47
4.3.4 HEAT PUMP HEATING MODE: (-)H2VZ/(-)H3VZ	47
4.3.5 HEAT PUMP HEATING MODE: (-)HMOVZ	48
4.3.6 SUPPLEMENTAL ELECTRIC HEAT DURING DEFROST (HEAT PUMP)	48
4.3.7 EMERGENCY HEAT (HEAT PUMP)	48
4.3.8 THERMOSTAT FAN SETTING	49
4.4 CORRECTING ELECTRIC HEAT KW FOR VOLTAGE	49
4.5 CALCULATING ELECTRIC HEAT CAPACITY IN BTU/HR	49
4.5.1 ESTIMATING AIR-FLOW USING ELECTRIC HEAT TEMPERATURE RISE	49
4.6 CHECKING REFRIGERANT CHARGE	49
5.0 COMPONENTS & CONTROLS	50
5.1 ECONETTM AIR-HANDLER CONTROL BOARD	50
5.2 ELECTRONIC EXPANSION VALVE (EXV)	50
5.2.1 EXV OVERVIEW	50
5.3 VAPOR LINE TEMPERATURE SENSOR (THERMISTOR)	51
5.4 SUCTION PRESSURE TRANSDUCER	51
5.5 THERMAL EXPANSION VALVE (TXV)	51
5.6 BLOWER	51
5.7 TRANSFORMER	51
5.8 INDOOR COIL ASSEMBLY	51
6.0 ACCESSORIES & KITS	52
6.1 ELECTRIC RESISTANCE HEATER KITS	52
6.2 JUMPER BAR KITS	52
6.3 AUXILIARY HORIZONTAL OVERFLOW PANS	52
6.4 EXTERNAL FILTER BASES	52
6.5 COMBUSTIBLE FLOOR BASES	53
6.6 HORIZONTAL ADAPTER KITS	53
7.0 MAINTENANCE	54
7.1 AIR FILTER	54
7.2 INDOOR COIL, DRAIN PAN, DRAIN LINE	54
7.3 BLOWER MOTOR AND WHEEL	54
7.4 MOTOR LUBRICATION	54
7.5 BLOWER ASSEMBLY REMOVAL & REPLACEMENT	54
7.6 MOTOR REPLACEMENT	55
7.7 MOTOR CONTROL MODULE REPLACEMENT	56
7.8 BLOWER WHEEL REPLACEMENT	56
7.9 ECONETTM AIR HANDLER CONTROL BOARD REPLACEMENT	56
7.10 REPLACEMENT PARTS	57
8.0 DIAGNOSTICS	58
8.1 GENERAL DIAGNOSTICS	58
8.2 ECONETTM AIR-HANDLER CONTROL BOARD DIAGNOSTIC CODES	59
9.0 WIRING DIAGRAMS	60
9.1 WIRING DIAGRAM	60

⚠ WARNING (SEE SECTION 3.12: ELECTRICAL WIRING)

Disconnect all power to unit before installing or servicing. More than one disconnect switch may be required to de-energize the equipment. Hazardous voltage can cause severe personal injury or death.

⚠ WARNING (SEE SECTION 7.5: BLOWER ASSEMBLY REMOVAL & REPLACEMENT)

If removal of the blower assembly is required, all disconnect switches supplying power to the equipment must be de-energized and locked (if not in sight of unit) so the field power wires can be safely removed from the blower assembly. Failure to do so can cause electrical shock resulting in personal injury or death.

⚠ WARNING

Because of possible damage to equipment or personal injury, installation, service, and maintenance should be performed by a trained, qualified service personnel. Consumer service is recommended only for filter cleaning/replacement. Never operate the unit with the access panels removed.

1.0 SAFETY INFORMATION

⚠ WARNING

Duct leaks can create an unbalanced system and draw pollutants such as dirt, dust, fumes and odors into the home causing property damage. Fumes and odors from toxic, volatile or flammable chemicals, as well as automobile exhaust and carbon monoxide (CO), can be drawn into the living space through leaking ducts and unbalanced duct systems causing personal injury or death (see Figure 1).

- If air-moving equipment or ductwork is located in garages or off-garage storage areas - all joints, seams, and openings in the equipment and duct must be sealed to limit the migration of toxic fumes and odors including carbon monoxide from migrating into the living space.
- If air-moving equipment or ductwork is located in spaces containing fuel burning appliances such as water heaters or boilers - all joints, seams, and openings in the equipment and duct must also be sealed to prevent depressurization of the space and possible migration of combustion byproducts including carbon monoxide into the living space.

⚠ WARNING

These instructions are intended as an aid to qualified, licensed service personnel for proper installation, adjustment and operation of this unit. Read these instructions thoroughly before attempting installation or operation. Failure to follow these instructions may result in improper installation, adjustment, service or maintenance possibly resulting in fire, electrical shock, property damage, personal injury or death.

⚠ WARNING (SEE SECTION 3.2.2: VERTICAL DOWNFLOW)

The RXHB-17, RXHB-21 or RXHB-24 combustible floor base is required when some units with electric heat are applied downflow on combustible flooring. Failure to use the base can cause a fire resulting in property damage, personal injury or death. See **CLEARANCES** (Section 3.4) for units requiring a combustible floor base. See the accessory section in this manual for combustible floor base RXHB.

⚠ WARNING (SEE SECTION 3.12.2: GROUNDING)

The unit must be permanently grounded. Failure to do so can result in electrical shock causing personal injury or death.

⚠ WARNING (SEE SECTION 7.0: MAINTENANCE)

Units with circuit breaker(s) meet requirements as a service disconnect switch, however, if access is required to the line side (covered) of the circuit breaker, this side of the breaker(s) will be energized with the breaker(s) de-energized. Contact with the line side can cause electrical shock resulting in personal injury or death.

⚠ WARNING (SEE SECTION 3.6: DUCTWORK)

Do not, under any circumstances, connect return ductwork to any other heat producing device such as fireplace insert, stove, etc. Unauthorized use of such devices may result in fire, carbon monoxide poisoning, explosion, personal injury or property damage.

Continued on next page >

WARNING

PROPOSITION 65: This appliance contains fiberglass insulation. Respirable particles of fiberglass are known to the State of California to cause cancer.

All manufacturer products meet current Federal OSHA Guidelines for safety. California Proposition 65 warnings are required for certain products, which are not covered by the OSHA standards.

California's Proposition 65 requires warnings for products sold in California that contain or produce any of over 600 listed chemicals known to the State of California to cause cancer or birth defects such as fiberglass insulation, lead in brass, and combustion products from natural gas.

All "new equipment" shipped for sale in California will have labels stating that the product contains and/or produces Proposition 65 chemicals. Although we have not changed our processes, having the same label on all our products facilitates manufacturing and shipping. We cannot always know "when, or if" products will be sold in the California market.

You may receive inquiries from customers about chemicals found in, or produced by, some of our heating and air-conditioning equipment, or found in natural gas used with some of our products. Listed below are those chemicals and substances commonly associated with similar equipment in our industry and other manufacturers.

- Glass Wool (Fiberglass) Insulation
- Carbon Monoxide (CO).
- Formaldehyde
- Benzene

More details are available at the websites for OSHA (Occupational Safety and Health Administration), at www.osha.gov and the State of California's OEHHA (Office of Environmental Health Hazard Assessment), at www.oehha.org. Consumer education is important since the chemicals and substances on the list are found in our daily lives. Most consumers are aware that products present safety and health risks, when improperly used, handled and maintained.

WARNING (SEE SECTION 3.7: RETURN AIR FILTER)

Do not operate the system without filters. A portion of the dust entrained in the air may temporarily lodge in the duct runs and at the supply registers. Any circulated dust particles could be heated and charred by contact with the heating elements. This residue could soil ceilings, walls, drapes, carpets and other articles in the house.

Soot damage may occur even with filters in place when certain types of candles, oil lamps or standing pilots are burned.

WARNING

The first 36 inches [91 cm] of supply air plenum and ductwork must be constructed of sheet metal as required by NFPA 90B. The supply air plenum or duct must have a solid sheet metal bottom directly under the unit with no openings, registers or flexible air ducts located in it. If flexible supply air ducts are used they may be located only in the vertical walls of a rectangular plenum, a minimum of 6 inches from the solid bottom. Metal plenum or duct may be connected to the combustible floor base, if not, it must be connected to the unit supply duct flanges such that combustible floor or other combustible material is not exposed to the supply air opening from the downflow unit. Exposing combustible (non-metal) material to the supply opening of a downflow unit can cause a fire resulting in property damage, personal injury or death.

Exceptions to downflow warnings:

- Installations on concrete floor slab with supply air plenum and ductwork completely encased in not less than 2 inches [5.1 cm] of concrete (See NFPA 90B).

CAUTION (SEE SECTION 3.2.2: VERTICAL DOWNFLOW & HORIZONTAL RIGHT DISCHARGE)

Unit must be reconfigured for vertical down or horizontal right supply air discharge applications. The coil must be repositioned so the vertical drainpan is on the bottom for vertical down discharge applications or the horizontal drip pan is below coil for horizontal right discharge applications. Failure to reconfigure the unit for these applications can result in property damage and poor system performance.

CAUTION (SEE SECTION 3.3: AUXILIARY OVERFLOW PAN)

In compliance with recognized codes, an auxiliary drain pan must be installed under all equipment containing evaporator coils that are located in any area of a structure where damage to the building or building contents may occur as a result of an overflow of the coil drain pan or a stoppage in the primary condensate drain piping. See Section 6.3 of this manual for auxiliary horizontal overflow pan accessory information (model RXBM).

NOTICE

When used in cooling applications, excessive sweating may occur when unit is installed in an unconditioned space. This can result in property damage.

NOTICE

Improper installation, or installation not made in accordance with the Underwriters Laboratory (UL) certification or these instructions, can result in unsatisfactory operation and/or dangerous conditions and are not covered by the unit warranty.

⚠ NOTICE

Use of this air-handler during construction is not recommended. If operation during construction is absolutely required, the following temporary installation requirements must be followed:

Installation must comply with all Installation Instructions in this manual including the following items:

- Properly sized power supply and circuit breaker/fuse
- Air-handler operating under thermostatic control;
- Return air duct sealed to the air-handler;
- Air filters must be in place;
- Correct air-flow setting for application
- Removing the coil and storing it in a clean safe place is highly recommended until construction is completed and the outdoor unit is installed.
- Clean air-handler, duct work, and components including coil upon completion of the construction process and verify proper air-handler operating conditions according as stated in this instruction manual.
- NOTE: Electric strip heater elements tend to emit a burning odor for a few days if dust has accumulated during construction. Heater elements are easily damaged. Take great care when cleaning them. Low pressure compressed air is recommended for cleaning elements.

FIGURE 1
MIGRATION OF DANGEROUS SUBSTANCES, FUMES, AND ODORS INTO LIVING SPACES

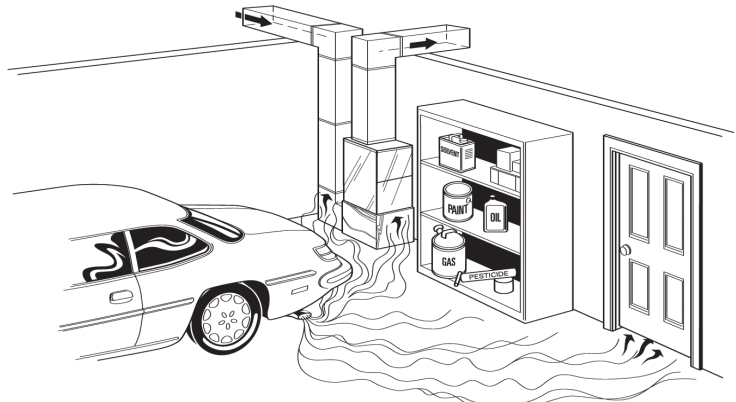

Adapted from *Residential Duct Diagnostics and Repair*, with permission of Air Conditioning Contractors of America (ACCA).

⚠ WARNING



Carbon Monoxide (CO) Poisoning Can Cause Severe Injury or Death.

Carbon Monoxide from the exhaust of motor vehicles and other fuel burning devices can be drawn into the living space by the operation of the central heating and air conditioning system.

Exhaust from motor vehicles, generators, garden tractors, mowers, portable heaters, charcoal and gas grills, gasoline powered tools, and outdoor camping equipment contains carbon monoxide, a poisonous gas that can kill you. You cannot see it, smell it, or taste it.

- Do NOT operate an automobile or any engine in a garage for more than the few seconds it takes to enter or exit the garage.
- Do NOT operate any fuel-burning device in an enclosed or partly enclosed space, or near building windows, doors or air intakes.

The U.S. Consumer Product Safety Commission (CPSC) and Health Canada recommend the installation of UL or CSA certified Carbon Monoxide Alarm(s) in every home.

⚠ WARNING

Duct leaks can create an unbalanced system and draw pollutants such as dirt, dust, fumes and odors into the home causing property damage. Fumes and odors from toxic, volatile or flammable chemicals, as well as automobile exhaust and carbon monoxide (CO), can be drawn into the living space through leaking ducts and unbalanced duct systems causing personal injury or death (see Figure 1).

- If air-moving equipment or ductwork is located in garages or off-garage storage areas - all joints, seams, and openings in the equipment and duct must be sealed to limit the migration of toxic fumes and odors including carbon monoxide from migrating into the living space.
- If air-moving equipment or ductwork is located in spaces containing fuel burning appliances such as water heaters or boilers - all joints, seams, and openings in the equipment and duct must also be sealed to prevent depressurization of the space and possible migration of combustion byproducts including carbon monoxide into the living space.

⚠ NOTICE

Improper installation, or installation not made in accordance with the Underwriters Laboratory (UL) certification or these instructions, can result in unsatisfactory operation and/or dangerous conditions and are not covered by the unit warranty.

2.0 GENERAL INFORMATION

2.1 IMPORTANT INFORMATION ABOUT EFFICIENCY & INDOOR AIR QUALITY

Central cooling and heating equipment is only as efficient as the duct system that carries the cooled or heated air. To maintain efficiency, comfort and good indoor air quality,

it is important to have the proper balance between the air being supplied to each room and the air returning to the cooling and heating equipment.

Proper balance and sealing of the duct system improves the efficiency of the heating and air conditioning system and improves the indoor air quality of the home by reducing the amount of airborne pollutants that enter homes from spaces where the ductwork and/or equipment is located. The manufacturer and the U.S. Environmental Protection Agency's Energy Star Program recommend that central duct systems be checked by a qualified contractor for proper balance and sealing.

2.2 CHECKING PRODUCT RECEIVED

Immediately upon receipt, all cartons and contents should be inspected for transit damage. Units with damaged cartons should be opened immediately. If damage is found, it should be noted on the delivery documents and a damage claim filed with the delivering carrier.

After unit has been delivered to the job site, remove the unit from the carton taking care not to damage the unit. Check the unit rating plate for unit model number, unit size, coil model, voltage, phase, etc. to assure the unit matches the job specifications.

2.3 MODEL NUMBER NOMENCLATURE

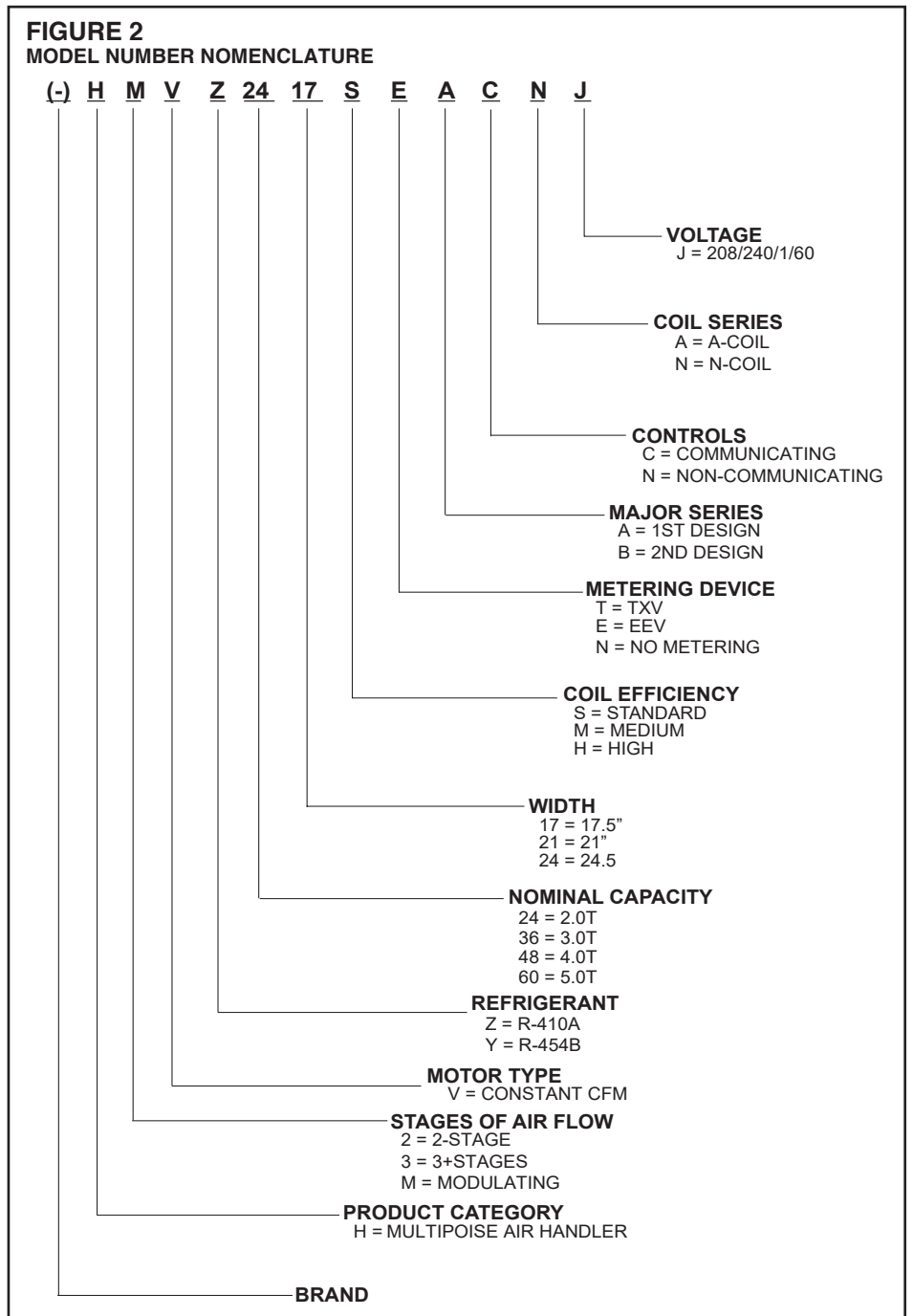

2.4 AVAILABLE MODELS

AVAILABLE MODELS: J VOLTAGE

(-)H2VZ2417STANNJ
(-)H2VZ3617STANNJ
(-)H2VZ3621STANNJ
(-)H2VZ3621MTANAJ
(-)H2VZ3621MTANNJ
(-)H2VZ4821STANNJ
(-)H2VZ4821STANAJ
(-)H2VZ4824STANNJ
(-)H2VZ6021STANAJ
(-)H2VZ6024STANNJ
(-)H3VZ2417STA(-)NJ
(-)H3VZ3617STA(-)NJ
(-)H3VZ4821STA(-)NJ
(-)H3VZ6024STA(-)NJ
(-)HMOVZ2417SEACNJ
(-)HMOVZ2421HEACAJ
(-)HMOVZ2421HEACNJ
(-)HMOVZ2421MEACNJ
(-)HMOVZ6021SEACAJ
(-)HMOVZ6024SEACNJ
(-)H3VZ2417MTACNJ
(-)H3VZ3621MTACNJ
(-)H3VZ4824STACNJ

2.5 DIMENSIONS & WEIGHTS

FIGURE 3
DIMENSIONS AND WEIGHTS

NOTE: 24" [61 cm] CLEARANCE REQUIRED IN FRONT OF UNIT FOR FILTER AND COIL MAINTENANCE.

HIGH VOLTAGE CONNECTION 7/8", 1 3/32", 1 31/32" [22.2 mm, 27.8 mm, 50.0 mm] DIA. KNOCK OUTS.

ELECTRICAL CONNECTIONS MAY EXIT TOP OR EITHER SIDE

LOW VOLTAGE CONNECTION 5/8" [18.9 mm] AND 7/8" [22.2 mm] KNOCK OUT (OUTSIDE OF CABINET)

Return Air Opening Dimensions

Model Cabinet Size	Return Air Opening Width -Inches [cm]	Return Air Opening Depth/Length -Inches [cm]
17	15 7/8 [40.3]	19 3/4 [50.2]
21	19 3/8 [49.2]	19 3/4 [50.2]
24	22 7/8 [58.1]	19 3/4 [50.2]

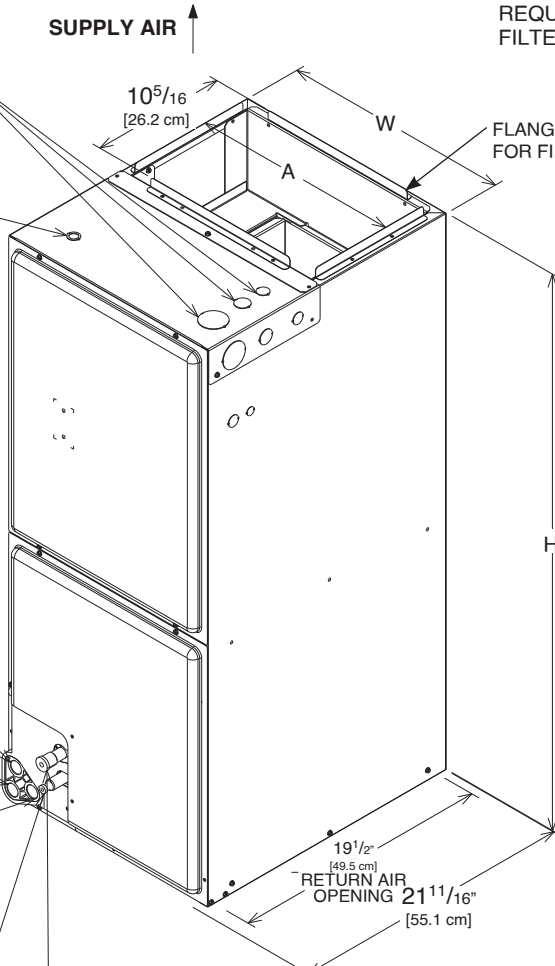

AUXILIARY DRAIN CONNECTION 3/4" [19.1 mm] FEMALE PIPE THREAD (NPT) HORIZONTAL APPLICATION ONLY

PRIMARY DRAIN CONNECTION 3/4" [19.1 mm] FEMALE PIPE THREAD (NPT)

AUXILIARY DRAIN CONNECTION 3/4" [19.1 mm] FEMALE PIPE THREAD (NPT) UPFLOW/DOWNFLOW APPLICATION ONLY

LIQUID LINE CONNECTION COPPER (SWEAT)

VAPOR LINE CONNECTION COPPER (SWEAT)

UPFLOW UNIT SHOWN; UNIT MAY BE INSTALLED UPFLOW, DOWNFLOW. HORIZONTAL RIGHT, OR LEFT AIR SUPPLY.

A-1038-01

DIMENSIONAL DATA

Model Family	Model Size	Refrigerant Connections Sweat (In.) [mm] ID		Unit Width "W" In. [mm]	Unit Height "H" In. [mm]	Supply Duct "A" In. [mm]	Unit Weight/Shipping Weight (Lbs.) [kg]
		Liquid	Vapor				
(-)H2VZ	2417STANN	3/8 [9.53]	3/4 [19.05]	17 1/2 [445]	42 1/2 [1080]	16 [406]	91/105 [41/48]
	3617STANN	3/8 [9.53]	3/4 [19.05]	17 1/2 [445]	42 1/2 [1080]	16 [406]	98/112 [44/51]
	3621STANN	3/8 [9.53]	3/4 [19.05]	21 [533]	42 1/2 [1080]	19 1/2 [495]	103/118 [47/54]
	3621MTANN	3/8 [9.53]	7/8 [22.23]	21 [533]	50 1/2 [1282]	19 1/2 [495]	126/142 [57/64]
	3621MTANA	3/8 [9.53]	7/8 [22.23]	21 [533]	57 [1448]	19 1/2 [495]	138/150 [63/68]
	4821STANN	3/8 [9.53]	7/8 [22.23]	21 [533]	50 1/2 [1282]	19 1/2 [495]	128/144 [56/65]
	4821STANA	3/8 [9.53]	7/8 [22.23]	21 [533]	57 [1448]	19 1/2 [495]	140/152 [64/69]
	4824STANN	3/8 [9.53]	7/8 [22.23]	24 1/2 [622]	55 1/2 [1410]	23 [584]	142/160 [64/73]
(-)H3VZ	6021STANA	3/8 [9.53]	7/8 [22.23]	21 [533]	57 [1448]	19 1/2 [495]	140/152 [64/69]
	6024STANN	3/8 [9.53]	7/8 [22.23]	24 1/2 [622]	55 1/2 [1410]	23 [584]	159/176 [72/80]
	2417STA(-)N	3/8 [9.53]	3/4 [19.05]	17 1/2 [445]	42 1/2 [1080]	16 [406]	91/105 [41/48]
	2417MTA(-)N	3/8 [9.53]	3/4 [19.05]	17 1/2 [445]	42 1/2 [1080]	16 [406]	91/105 [41/48]
	3617STA(-)N	3/8 [9.53]	3/4 [19.05]	17 1/2 [445]	42 1/2 [1080]	16 [406]	99/113 [45/51]
	3621MTA(-)N	3/8 [9.53]	7/8 [22.23]	21 [533]	50 1/2 [1282]	19 1/2 [495]	129/145 [59/66]
(-)HMVZ	4821STA(-)N	3/8 [9.53]	7/8 [22.23]	21 [533]	50 1/2 [1282]	19 1/2 [495]	129/145 [59/66]
	4824STA(-)N	3/8 [9.53]	7/8 [22.23]	24 1/2 [622]	55 1/2 [1410]	23 [584]	158/175 [72/79]
	6024STA(-)N	3/8 [9.53]	7/8 [22.23]	24 1/2 [622]	55 1/2 [1410]	23 [584]	158/175 [72/79]
	2417SEACN	3/8 [9.53]	3/4 [19.05]	17 1/2 [445]	42 1/2 [1080]	16 [406]	91/105 [41/48]
	2421MEACN	3/8 [9.53]	3/4 [19.05]	21 [533]	42 1/2 [1080]	19 1/2 [495]	103/118 [47/54]
	2421HEACN	3/8 [9.53]	7/8 [22.23]	21 [533]	50 1/2 [1282]	19 1/2 [495]	123/139 [56/63]
	2421HEACA	3/8 [9.53]	7/8 [22.23]	21 [533]	57 [1448]	19 1/2 [495]	140/152 [64/69]
	6021SEACA	3/8 [9.53]	7/8 [22.23]	21 [533]	57 [1448]	19 1/2 [495]	140/152 [64/69]
	6024SEACN	3/8 [9.53]	7/8 [22.23]	24 1/2 [622]	55 1/2 [1410]	23 [584]	159/176 [72/80]

2.6 IMPORTANCE OF PROPER INDOOR/ OUTDOOR MATCH-UPS

To assure many years of reliable operation and optimum customer comfort and to assure the outdoor unit warranty remains valid, an air-handler model should be selected that is properly matched to the outdoor unit. This is especially critical for heat pump systems to assure proper refrigerant charge balance between the cooling and heating modes. The recommended approach is to select an air-handler model that has an AHRI match with the outdoor unit. Refer to the AHRI directory at www.ahridirectory.org to confirm the air-handler and outdoor unit are a certified combination in the AHRI Directory.

2.7 IMPORTANCE OF QUALITY INSTALLATION

A quality installation is critical to assure safety, reliability, comfort, and customer satisfaction. Strict adherence to applicable codes, the information in this installation manual, the outdoor unit installation manual, and the thermostat installation manual are key to a quality installation. Read the entire instruction manuals before starting the installation.

IMPORTANT: This product has been designed and manufactured to meet certified AHRI capacity and efficiency ratings with the appropriate outdoor units. However, proper refrigerant charge, proper airflow, and refrigerant line sizing are critical to achieve optimum capacity and efficiency and to assure reliable operation. Installation of this product should follow the manufacturer's refrigerant charging and airflow instructions located in the outdoor unit installation instructions and the charging chart label affixed to the outdoor unit. Failure to confirm proper charge and airflow may reduce energy efficiency and shorten equipment life.

The equipment has been evaluated in accordance with the Code of Federal Regulations, Chapter XX, Part 3280.

Install the unit in accordance with applicable national, state, and local codes. Latest editions are available from: "National Fire Protection Association, Inc., Batterymarch Park, Quincy, MA 02269." These publications are:

- ANSI/NFPA No. 70-(Latest Edition) National Electrical Code.
- NFPA90A Installation of Air Conditioning and Ventilating Systems.
- NFPA90B Installation of warm air heating and air conditioning systems.

Install the unit in such a way as to allow necessary access to the coil/filter rack and blower/control compartment.

3.0 INSTALLATION

3.1 TOOLS & REFRIGERANT

3.1.1 TOOLS REQUIRED FOR INSTALLING AND SERVICING R-410A MODELS

Manifold Sets:

- Up to 800 PSIG [5,516 kPa] High-Side
- Up to 250 PSIG [1,724 kPa] Low-Side
- 550 PSIG [3,792 kPa] Low-Side Retard

Manifold Hoses:

- Service Pressure Rating of 800 PSIG [5,516 kPa]

Recovery Cylinders:

- 400 PSIG [2,758 kPa] Pressure Rating
- Dept. of Transportation 4BA400 or BW400



NOTICE

R-410A systems operate at higher pressures than R-22 systems. Do not use R-22 service equipment or components on R-410A equipment.

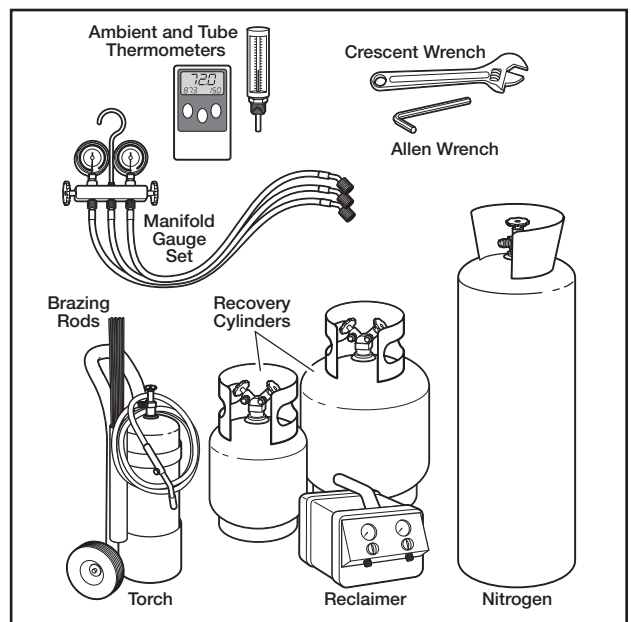

3.1.2 SPECIFICATIONS OF R-410A

Application: R-410A is not a drop-in replacement for R-22. Equipment designs must accommodate its higher pressures. It cannot be retrofitted into R-22 heat pumps.

Physical Properties: R-410A has an atmospheric boiling point of -62.9°F [-52.7°C] and its saturation pressure at 77°F [25°C] is 224.5 psig [1,548 kPa].

Composition: R-410A is a near-azeotropic mixture of 50% by weight difluoromethane (HFC-32) and 50% by weight pentafluoroethane (HFC-125).

Pressure: The pressure of R-410A is approximately 60% (1.6 times) greater than R-22. Recovery and recycle equipment, pumps, hoses, and the like must have design pressure ratings appropriate for R-410A. Manifold sets need to range up to 800 psig [5,516 kPa] high-side and 250 psig [1,724 kPa] low-side with a 550 psig [3,792 kPa] low-side retard. Hoses need to have a service pressure rating of 800 psig [5,516 kPa]. Recovery cylinders need to have a 400 psig [2,758 kPa] service pressure rating, DOT 4BA400 or DOT BW400.

Combustibility: At pressures above 1 atmosphere, a mixture of R-410A and air can become combustible. **R-410A and air should never be mixed in tanks or supply lines or be allowed to accumulate in storage tanks. Leak checking should never be done with a mixture of R-410A and air.** Leak-checking can be performed safely with nitrogen or a mixture of R-410A and nitrogen.

3.1.3 QUICK-REFERENCE GUIDE FOR R-410A

- R-410A refrigerant operates at approximately 60% higher pressure (1.6 times) than R-22. Ensure that servicing equipment is designed to operate with R-410A.
- R-410A refrigerant cylinders are light rose in color.
- R-410A, as with other HFCs, is only compatible with POE oils.
- Vacuum pumps will not remove moisture from POE oil used in R-410A systems.
- R-410A systems are to be charged with liquid refrigerants. Prior to March 1999, R-410A refrigerant cylinders had a dip tube. These cylinders should be kept upright for equipment charging. Post-March 1999 cylinders do not have a dip tube and should be inverted to ensure liquid charging of the equipment.
- Do not install a suction line filter drier in the liquid line.
- A factory-approved outdoor liquid line filter drier is shipped with every unit and must be installed in the liquid line at the time of installation. If only the air-handler is being replaced on an existing system, the existing filter drier must be replaced at the time of installation with a field supplied filter drier. **IMPORTANT:** A bi-flow filter drier must be used for heat pump applications. Filter driers must be rated for minimum working pressure of 600 psig. [4,137 kPa]. The filter drier will only have adequate moisture-holding capacity if the system is properly evacuated.
- Desiccant (drying agent) must be compatible for POE oils and R-410A refrigerant.

3.2 APPLICATIONS AND ORIENTATION

3.2.1 VERTICAL UPFLOW & HORIZONTAL LEFT DISCHARGE

- Vertical Upflow & Horizontal Left Discharge is the factory configuration for all models.
- The return air plenum must be large enough to supply unit and strong enough to support unit weight.
- If return air is to be ducted through the floor, install duct flush with floor. Use fireproof resilient gasket 1/8 to 1/4 in [3.2 to 6.4 mm]. thick between duct, unit and floor. Set unit on floor over opening.

IMPORTANT: Do not cut the side out of air-handler cabinet for a side return duct as this will result in the return air bypassing the coil. Instead, install air-handler on top of a field supplied sheet metal or wooden box and run the side return duct into the side of the box.

3.2.2 VERTICAL DOWNFLOW & HORIZONTAL RIGHT DISCHARGE

The unit as shipped from the factory is not configured for vertical down or horizontal right discharge applications and must be converted in the field to work in those applications. To make this conversion, remove the coil door and slide the indoor coil out of the cabinet. (See Figure 6)

When converting the air-handler for vertical down and horizontal right discharge applications, an additional set of 2 coil support rails must be installed before the coil can be reinstalled. These additional rails are supplied with the air-handler and are packaged with the duct flanges. Six screws are also provided for mounting the rails and can be found in the installation hardware bag. Clearance holes must be drilled in the sides of the cabinet for the mounting screws using the provided dimples as guides. Note that the shorter coil support rail with no notch must be mounted on the left-hand side to provide clearance for the drainpan condensate connection boss.

FIGURE 4
DIMENSIONS FOR REFRIGERANT-TUBING & DRAIN CONNECTIONS

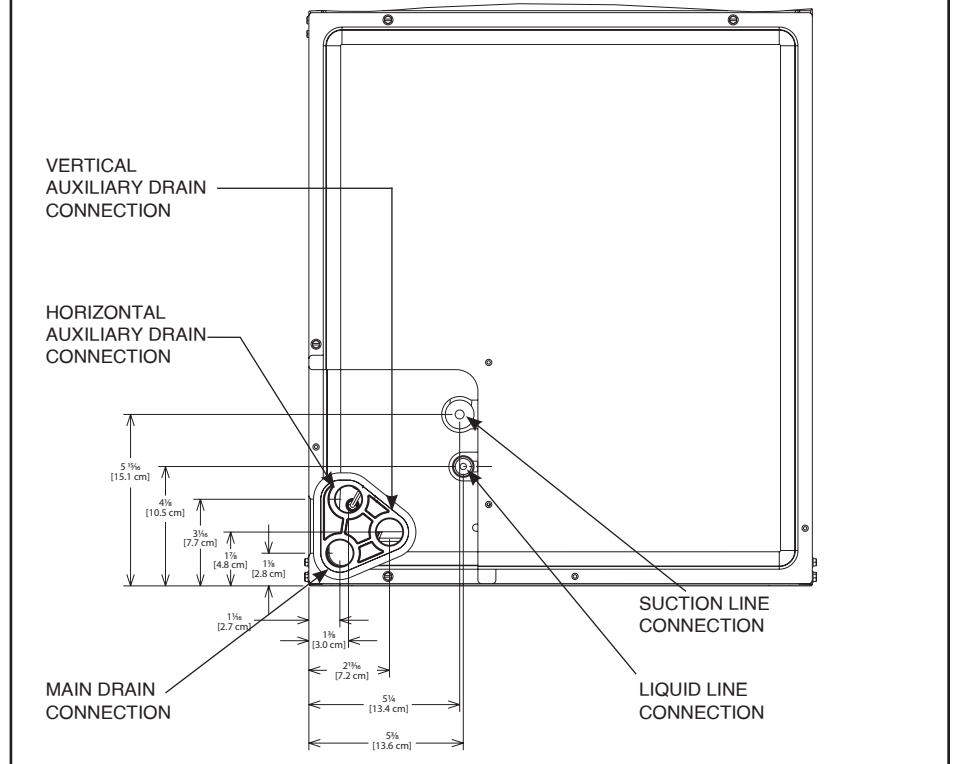

The vertical down/horizontal right coil support rails were not installed at the factory so the insulation under them would not be compressed which could result in exterior cabinet sweating in humid environments due to that location being in the cold downstream side of the indoor coil in vertical up and horizontal left discharge applications. The coil support rails installed at the factory should be left in place to help retain the cabinet insulation. They will be located on the warmer return side of the air-handler for down and horizontal right discharge applications and will therefore not pose a risk for cabinet sweating.

Once the additional coils support rails are installed, slide the coil back into the cabinet 180° from its original position, ensuring the retaining channel is fully engaged with the coil rail. (See Figure 6, Detail A.) Leave the coil door off until after the refrigerant tubing is brazed to the refrigerant stubs to allow TXV to be wrapped with a wet rag or heat sink compound during the brazing process. If the air-handler is not already in position, it can now be positioned so the blower discharge is either down or to the right depending on the application.

DRIP LOOP NOTE: When installing the unit in down or horizontal right discharge applications, make sure the wires going to the blower motor form a proper drip loop to force any condensate that might form on the wires to drip off the lowest point of the wiring instead of entering the motor or motor control. This may require cutting the wire-tie and installing a new wire-tie to form a new drip loop.

IMPORTANT: To comply with certification agencies and the National Electric Code for down discharge applications, the circuit breaker(s) on field-installed electric heater kits must be re-installed per procedure below so that the breaker switch “on” position and marking is up and the “off” position and marking is down.

- To turn breaker(s): Rotate one breaker pair (circuit) at a time starting with the one on the right. Loosen both lugs on the load side of the breaker. Wires are bundles with wire ties, one bundle going to the right lug and one bundle going to the left lug.
- Using a screwdriver or pencil, lift white plastic tab with hole away from breaker until breaker releases from mounting opening (see Figure 5).
- With breaker held in hand, rotate breaker so that “on” position is up and the “off” position is down with unit in the vertical mounting position. Insert right wire bundle into top right breaker lug, ensuring all strands of all wires are inserted fully into lug, and no wire insulation is caught in lug.
- Tighten lug as tight as possible while holding circuit breaker. Check wires and make sure each wire is secure and none are loose. Repeat for left wire bundle in left top circuit breaker lug.

IMPORTANT: Failure to securely hold the breaker will result in the plastic mounting boss on the breaker to be broken off when the lug is tightened.

- Replace breaker by inserting breaker mounting tab opposite white pull tab in opening, hook mounting tab over edge in opening.

FIGURE 5
ROTATING CIRCUIT BREAKER

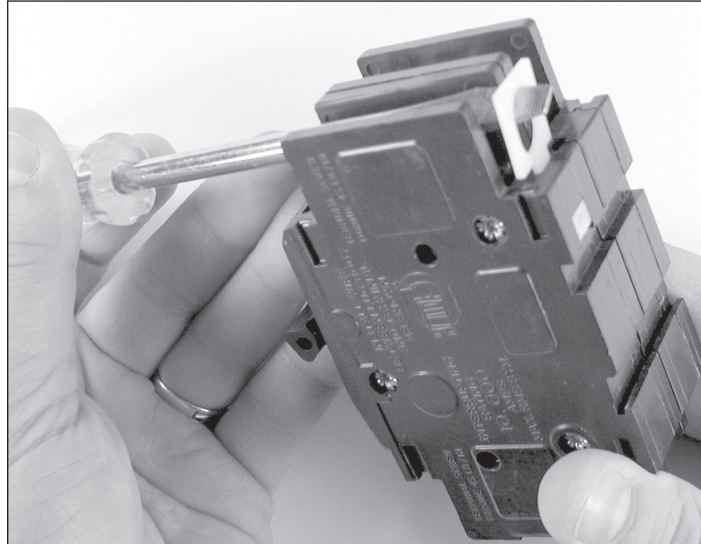

- With screwdriver or pencil, pull white tab with hole away from breaker while setting that side of breaker into opening. When breaker is in place, release tab, locking circuit breaker into location in opening.
- Repeat above operation for remaining breaker(s) (if more than one is provided).
- If one is used, replace the single point wiring jumper bar on line side of breaker and tighten securely.
- Double check wires and lugs to make sure all are secure and tight. Check to make sure unit wiring to circuit breaker load lugs match that shown on the unit wiring diagram.

⚠ WARNING

The RXHB-17, RXHB-21 or RXHB-24 combustible floor base is required when some units with electric heat are applied downflow on combustible flooring. Failure to use the base can cause a fire resulting in property damage, personal injury or death. See CLEARANCES (Section 3.4) for units requiring a combustible floor base. See the accessory section in this manual for combustible floor base RXHB.

IMPORTANT: Units cannot be installed horizontally laying on or suspended from the back of the unit.

⚠ CAUTION

Auxiliary horizontal overflow pan kits RXBM- (or equivalent) are required when the unit is configured for the horizontal position over a finished ceiling and/or living space. (See Sections 3.3 and 6.3.) Failure to install overflow pan can result in property damage.

3.2.3 INSTALLATION IN AN UNCONDITIONED SPACE

The exterior cabinet of an air handler has a greater risk of sweating when installed in an unconditioned space than when it is installed in the conditioned space. This is primarily due to the temperature of the conditioned air moving through the air handler and the air circulating around the unit where it is installed. For this reason, the following is recommended for all air handler applications, but special attention should be paid to those installed in unconditioned spaces:

1. Duct sizing and airflow are critical and must be based on the equipment selected.
2. Supply and return duct attachment: If other than the factory flanges are used, the attachment of ducting must be insulated and tight to prevent sweating.
3. No perimeter supply flanges are provided. If a full perimeter supply duct is used, it is the responsibility of the installer to provide duct flanges as needed, to secure and seal the supply duct to prevent air leakage and the sweating that will result.
4. Apply caulking around all cabinet penetrations such as power wires, control wires, refrigerant tubing and condensate line where they enter the cabinet. Seal the power wires on the inside where they exit conduit opening. Sealing is required to prevent air leakage into the unit which can result in condensate forming inside the unit, control

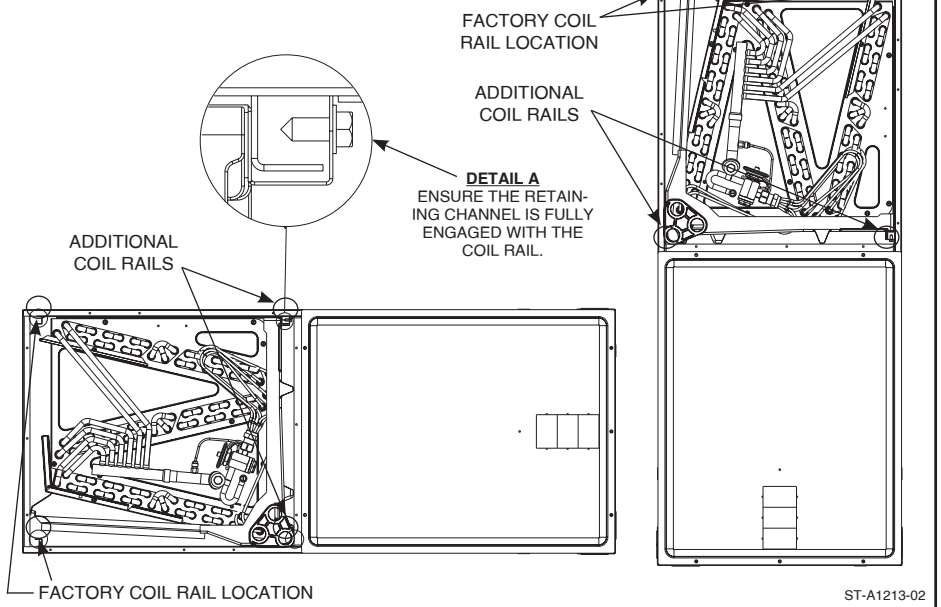
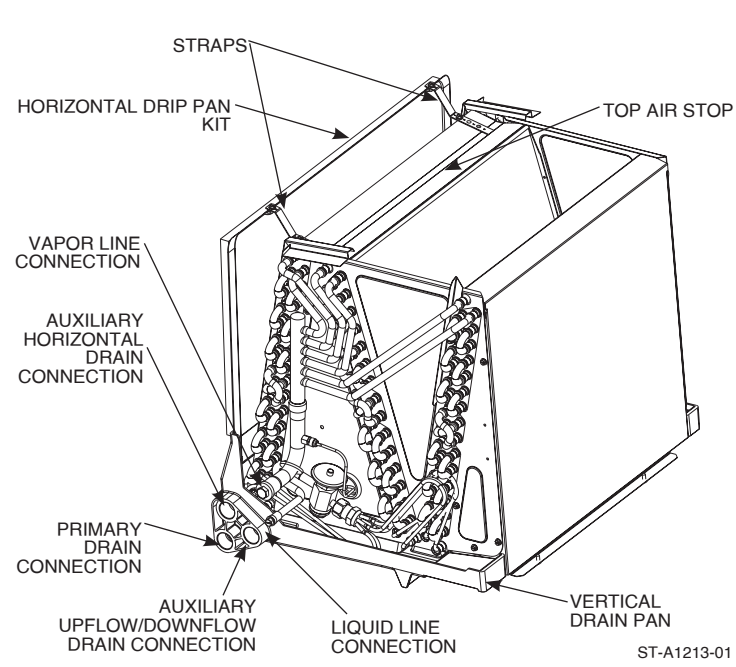
FIGURE 6**VERTICAL DOWNFLOW & HORIZONTAL RIGHT APPLICATIONS****FIGURE 7****INDOOR COIL AND DRAIN PAN DETAILS**

box, and on electrical controls. Take care not to damage, remove or compress insulation when applying the caulk.

5. In some cases, the entire air handler can be wrapped with insulation. This can be done as long as the unit is completely enclosed in insulation, sealed and service access is provided to prevent accumulation of moisture inside the insulation wrap.
6. An auxiliary overflow pan is recommended to protect the structure from excessive cabinet sweating or a restricted coil drain line. (See Section 3.3)
7. If an electric heater kit is installed, be sure the breaker or disconnect cover is sealed tightly to the door panel.

3.2.4 INSTALLATION IN MOBILE/MANUFACTURED HOMES

1. Air handler must be secured to the structure using "L" brackets or pipe strap.
2. Allow a minimum of 24 inches [61 cm] front clearance required to access doors.
3. Recommended method for securing air handler:
 - A. If air handler is against the wall, secure top of air handler to wall stud using two

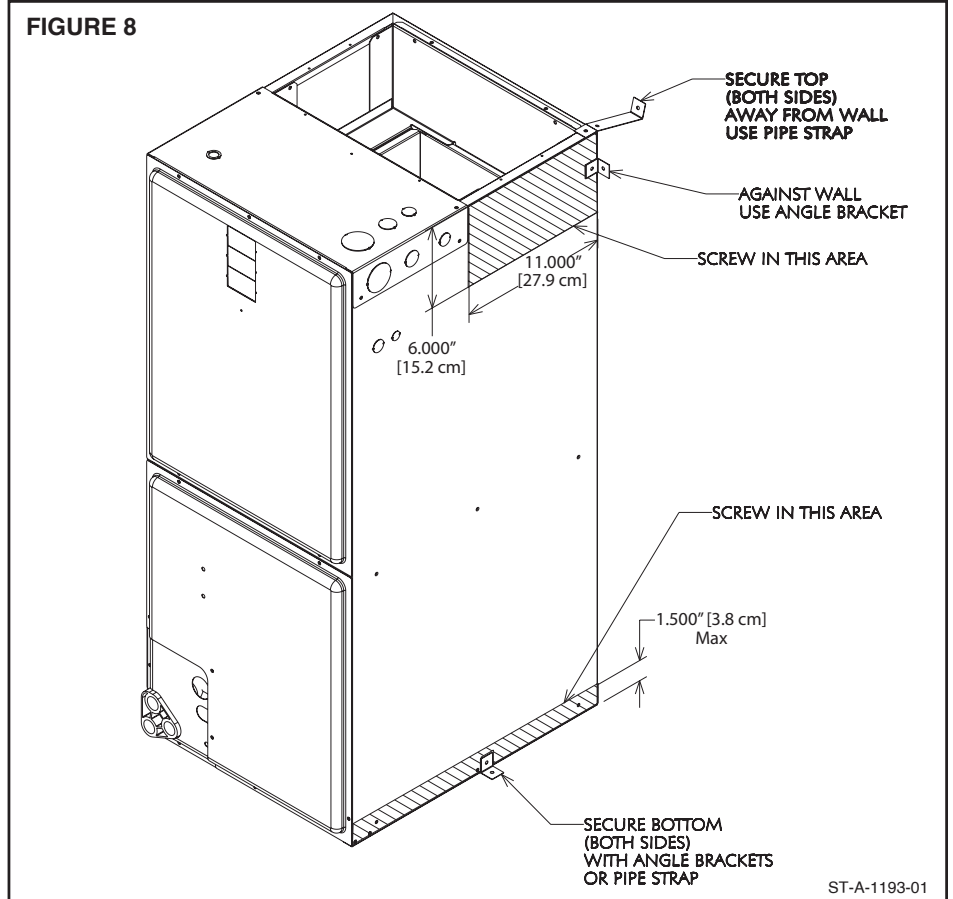
FIGURE 8

16ga thick angle brackets one on each side. Attach brackets with No. 10 self-tapping $\frac{1}{2}$ " [13mm] long screws to air handler and use $\frac{5}{16}$ " [8 mm] lag screws $1\frac{1}{2}$ " [38 mm] long to wall stud. Secure bottom of unit with two 16ga "L" brackets with No. 10 self-tapping $\frac{1}{2}$ " [13 mm] long screws to air handler and use $\frac{5}{16}$ " [8 mm] lag screws $1\frac{1}{2}$ " [38 mm] long to floor.

- B. If air handler is away from wall attach pipe strap to top of air handler using No. 10 $\frac{1}{2}$ " [13 mm] long self-tapping screws on both sides. Angle strap down and away from back of air handler, remove all slack, and fasten to wall stud of structure using $\frac{5}{16}$ " [8 mm] lag screws $1\frac{1}{2}$ " [38 mm] long. Secure bottom of unit with two 16ga "L" brackets with No. 10 self-tapping screws to air handler and use $\frac{5}{16}$ " [8 mm] lag screws $1\frac{1}{2}$ " [38 mm] long to floor.

3.2.5 INSTALLATION IN CORROSIVE ENVIRONMENTS

The metal parts of this unit may be subject to rust or deterioration if exposed to a corrosive environment which can shorten its life. In addition to exposure to the exterior of the cabinet, chemical contaminants inside the building that can be drawn into the unit from the return air grille and attack structural metal parts, electrical components and the indoor coil, causing premature failure of the unit. If the unit is to be installed in an area where contaminants are likely to be a problem, special attention should be given to isolate the unit and return grille from contaminants.

3.2.6 SUPPORTING AIR-HANDLER IN HORIZONTAL APPLICATIONS

The air-handler must be adequately supported underneath if it is installed in the horizontal position to prevent it from sagging in the middle which can cause issues removing and re-installing the access panels. Position the unit on adequate supports or on support angles or channels (See Figure 9) before connecting ductwork to the unit. If an auxiliary overflow pan is required (See Section 3.3), the overflow pan will need to be adequately supported with the air-handler being supported underneath within the auxiliary overflow pan by angles and/or channels.

FIGURE 9

SUSPENDED HORIZONTAL AIR-HANDLER.

NOTE:
HORIZONTAL LEFT ORIENTATION
DEPICTED IN ILLUSTRATION.
HORIZONTAL RIGHT ORIENTATION
IS SIMILAR IN INSTALLATION.

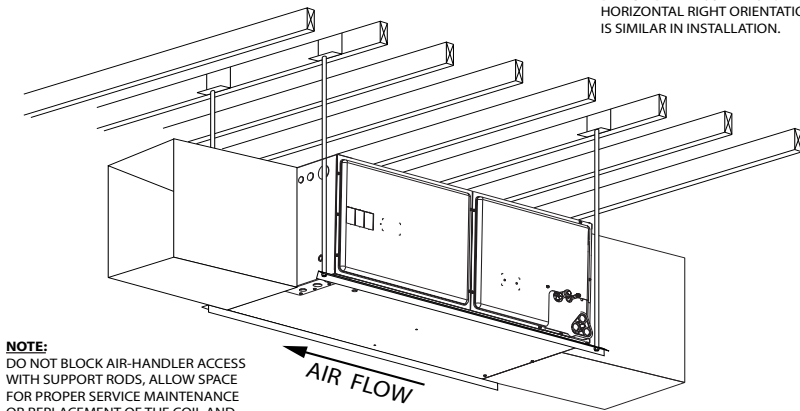

NOTE:
DO NOT BLOCK AIR-HANDLER ACCESS
WITH SUPPORT RODS, ALLOW SPACE
FOR PROPER SERVICE, MAINTENANCE
OR REPLACEMENT OF THE COIL AND
BLOWER ASSEMBLY.

**SUPPORTING HORIZONTAL AIR-HANDLERS IN AUXILIARY
OVERFLOW PANS OR AIR-HANDLERS THAT ARE NOT SUSPENDED.**

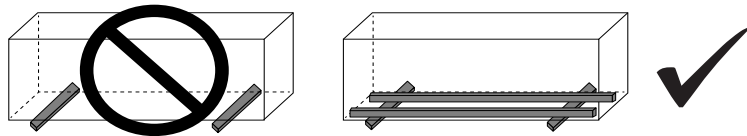

ST-A1298-01

3.3 AUXILIARY OVERFLOW PAN

In compliance with recognized codes, an auxiliary overflow pan must be installed under all equipment containing evaporator coils that are located in any area of a structure where damage to the building or building contents may occur as a result of an overflow of the coil drain pan or a stoppage in the primary condensate drain piping. See Section 6.3 of this manual for information regarding the recommended auxiliary horizontal overflow pan (model RXBM) for this air-handler.

3.4 CLEARANCES

- All units are designed for “0” inches [cm] clearance to combustible material on all cabinet surfaces except for downflow application with higher kW electric heat as noted below.
- Some units require a combustible floor base depending on the heating kW if installed in the downflow configuration on a combustible surface. The following table should be used to determine these requirements.

Model Cabinet Size	17	21	24
Maximum Model Designation kW	15	18	20

- Units with electric heating kW equal to or less than the values listed in the table do not require a combustible floor base. See Section 6.5 for Combustible Floor Base RXHB-XX.
- Units with electric heat require a one inch clearance to combustible material for the first three feet of supply plenum and ductwork.
- Vertical downflow applications require clearance on at least one side of the unit for electrical connections. Refrigerant and condensate drain connections are made on the front of the unit.
- All units require 24 inches [61 cm] minimum access to the front of the unit for service.
- These units may be installed in either ventilated or nonventilated spaces.

3.5 DUCT FLANGES

Duct flanges (4 pieces) are shipped with the unit and are to be field installed on the top of the air-handler using the following procedure and referring to Figure 10.

1. Loosen the screws attaching the heat barrier to the cabinet.
2. Form a 90° bend with the short leg length at approximately 9.9” [25.1 cm] from the end where the slot is cut in the flange to facilitate bending. The duct flanges are shipped sized for the 24.5” [62.2 cm] wide cabinet. For the 17.5” [44.5 cm] and 21” [53.3 cm] wide cabinets, cut the long leg as shown in Figure 10 to match the cabinet width.
3. Slide the duct flanges onto the screws loosened in step one above. Tighten the screws to secure the flanges.

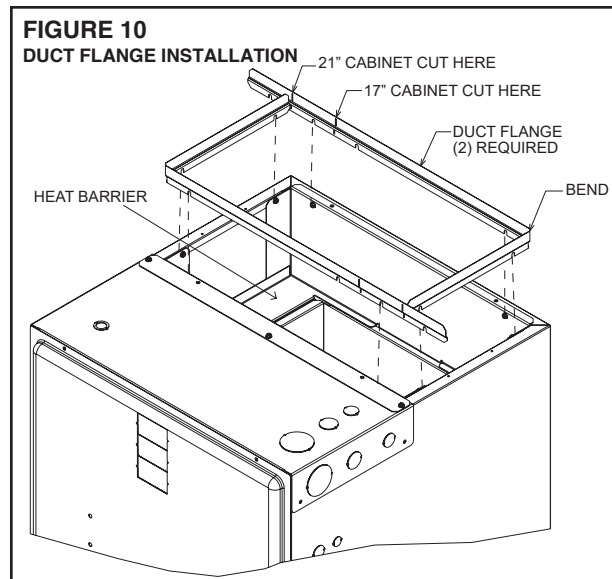

3.6 DUCTWORK

Field ductwork must comply with the National Fire Protection Association NFPA 90A, NFPA 90B and any applicable local ordinance.

WARNING

Do not, under any circumstances, connect return ductwork to any other heat producing device such as fireplace insert, stove, etc. Unauthorized use of such devices may result in fire, carbon monoxide poisoning, explosion, personal injury or property damage.

Sheet metal ductwork run in unconditioned spaces must be insulated and covered with a vapor barrier. Fibrous ductwork may be used if constructed and installed in accordance with SMACNA Construction Standard on Fibrous Glass Ducts. Ductwork must comply with National Fire Protection Association as tested by U/L Standard 181 for Class I Air Ducts. Check local codes for requirements on ductwork and insulation.

- Duct system must be designed within the range of external static pressure the unit is designed to operate against. It is important that the system airflow be adequate. Make sure supply and return ductwork, grills, filters, accessories, etc. are accounted for in total resistance. Refer to the airflow performance tables in this manual to determine the available external static pressure for the particular air-handler model being installed.
- Design the duct system in accordance with “ACCA” Manual “D” Design for Residential Winter and Summer Air Conditioning and Equipment Selection. Latest editions are available from: “ACCA” Air Conditioning Contractors of America, 1513 16th Street, N.W., Washington, D.C. 20036. If duct system incorporates **flexible air duct**, be sure **pressure drop** information (straight length plus all turns) shown in “ACCA” Manual “D” is accounted for in system.
- Supply plenum is attached to the duct flanges supplied with the unit. See Section 3.5.
- **IMPORTANT:** If an elbow is included in the plenum close to the unit, it must not be smaller than the dimensions of the supply duct flange on the unit.
- **IMPORTANT:** The front flange on the return duct if connected to the blower casing must not be screwed into the area where the power wiring is located. Drills or sharp screw points can damage insulation on wires located inside unit.
- Secure the supply and return ductwork to the unit flanges, using proper fasteners for the type of duct used and tape or caulk the duct-to-unit joint as required to prevent air leaks.

WARNING

Do not operate the system without filters. A portion of the dust entrained in the air may temporarily lodge in the duct runs and at the supply registers. Any circulated dust particles could be heated and charred by contact with the heating elements. This residue could soil ceilings, walls, drapes, carpets and other articles in the house. Operating the system without a filter will also allow lint and dirt particles to accumulate on the indoor coil fin and restrict air-flow through the coil. Soot damage may occur even with filters in place when certain types of candles, oil lamps or standing pilots are burned.

3.7 RETURN AIR FILTER

An internal filter rack is not provided with this air-handler. Therefore, an external means of filtering the return air is required. External filters should be sized for a maximum of 300 feet/min [1.5 m/s] air velocity or the maximum velocity recommended by the type of

filter installed. One or more return air filter grilles, a filter rack attached to unit return air intake, or a filter rack installed between a sealed return air platform and the return duct are all acceptable means of filtration. All return ducts must be filtered, either at each return grille or at a common filter near the unit.

Important: Do not install a return air filter grille and a filter rack at the unit and do not install a filter in the supply duct system.

Filter type, sizing, and placement are critical to heating and cooling system performance. Reduced air-flow can shorten the life of system components such as the compressor, indoor coil, heater elements, over temperature limits, and relays. As filters near the end of their useful life, the pressure drop through them increases. Therefore, it is important to factor the “end of life” (dirty) pressure drop of filters into the external static pressure of the duct system when selecting blower speeds and designing ductwork to assure the system is operating at the design CFM [L/s] and system reliability is not compromised. Always verify that the system’s air-flow is within specifications by performing a temperature rise (heating mode) and/or temperature drop (cooling mode) with all filters in place.

Important: High efficiency pleated filters and electronic air cleaners typically have significantly higher pressure drop than standard efficiency fiberglass filters, especially when they get dirty. Do not use high efficiency filters or electronic air cleaners unless adequate filter area is provided to lower the filter pressure drop to an acceptable level.

3.8 REFRIGERANT LINE CONNECTIONS & CHARGING

3.8.1 PREPARATION

The coil is shipped with a low pressure (5-10 psig or 34-68 kPa) charge of dry nitrogen which will be released when the rubber plugs are removed. Leave the rubber plugs in the refrigerant connection stubs on the air-handler until the refrigerant lines are ready to be brazed to the refrigerant connection stubs to prevent contaminants from entering the coil. Clean the ends of the tubing and coil connection stubs (inside and outside) with an alcohol wipe before inserting the line set tubes into the coil connection stubs to assure a quality leak-free braze joint.

Refer to the outdoor unit installation instructions for details on refrigerant line sizing and installation. Be sure to follow long line length guidelines if they apply.

Route the refrigerant tubing in a manner that does not block service access to the front of the air-handler.

3.8.2 LIQUID LINE FILTER DRIER

A new liquid filter drier must be installed every time any part of the system has been open to the atmosphere, even if it’s for a short period of time. The filter drier should be installed close to the air-handler for a system started up in the cooling mode and near the outdoor unit for a heat pump system started up in the heating mode. This allows the filter drier to catch any contaminants in the liquid line before they can enter the indoor or outdoor TXV inlet screen.

3.8.3 BRAZING

Air inside the tubing and coil should be displaced with dry nitrogen prior to the brazing process to prevent the formation of harmful copper oxide inside the tubing. It is very important not to pressurize the system with nitrogen while brazing or pin-hole leaks will form in the braze joint. This is accomplished by removing the gauge port valve core on one of the outdoor unit service valves to allow the pressure to be relieved as the heated nitrogen expands. Fill the system with dry nitrogen through the other service valve gauge port and then turn the nitrogen flow off just before brazing is begun.

Protect the TXV or EXV, copper to aluminum suction header joint, and outdoor unit service valves from overheating using a wet rag or heat sink compound. Leave the wet rag or heat sink material in place until the joint and surrounding tubing cools down to a safe temperature. Double tip torches can help minimize brazing time and heat conduction to the heat sensitive components if the flame is turned down and held on the joint just long enough to make the braze joint. With both single and double tip torches, turning the flame up too much and keeping the flame on the joint too long will damage the heat sensitive components even when a wet rag or heat sink compound is used.

Use a sheet metal shield to protect the cabinet’s paint from the torch flames during the brazing process. The vapor line insulation should be pushed back on the line about 12 inches [30.5 cm] from the joint and retained to prevent it from igniting or melting during the brazing process.

After the refrigerant brazed connections are made at the air-handler and the tubing has cooled down sufficiently, replace the coil section access panel if it has been removed and seal the air gap around the connection stubs with the foam rubber gasket included in the air-handler parts bag. Peel the self-adhesive backing off of the foam gasket and position it around the stubs with the adhesive side toward the cabinet, then press it firmly against the cabinet. The gasket is split to allow it to go over the stubs after the refrigerant tubes are brazed to the stubs. (See Figure 12B in Section 3.9)

After the foam gasket has been installed, the vapor line insulation should be pulled back in place so it contacts the air-handler cabinet to prevent condensate from forming on

the cold tube and dripping off. A loosely fitting zip-tie placed around the insulation ½” [13 mm] from the end can be used to hold it in place so it doesn’t move away from the cabinet. For air-handlers with TXV’s, a section of the insulation will need to be cut out to make room for the externally mounted TXV bulb. **(See Section 3.9)** Once the bulb is mounted, insulate the bulb with the foam insulation included in the air-handler parts bag, making sure none of the vapor line is uninsulated.

3.8.4 LEAK TESTING

After all braze joints are completed, replace the valve core removed when purging with nitrogen and then leak test the system by pressurizing to 150 psig [1,034 kPa] with dry nitrogen and allow the system to sit for at least 15 minutes (longer if possible) to assure the pressure does not drop.

3.8.5 EVACUATION

If no leaks are detected, evacuate the system down to 500 microns or below before charging the system or opening the service valves on the outdoor unit which will release the charge stored in the outdoor unit into the line set and air-handler coil. Failure to reach 500 microns of vacuum is a sign of a leak or excessive moisture inside the system.

3.8.6 REFRIGERANT CHARGING

Once the evacuation process is completed, break the vacuum with the refrigerant from a refrigerant cylinder or with refrigerant stored in the outdoor unit by opening the outdoor unit service valves. The charging process cannot be completed until the remaining steps in the installation process are completed and the indoor air-flow is adjusted to the proper level.

3.9 EXV VAPOR LINE THERMISTOR/TXV SENSING BULB ATTACHMENT

IMPORTANT: DO NOT perform any brazing with the vapor line thermister or TXV sensing bulb attached to any line. After brazing operations have been completed, clamp the vapor line thermister or TXV bulb securely on the vapor line at the 10 to 2 o’clock position (see Figures 11 and 12) with the clip provided on the thermister or TXV clamp provided in the air-handler parts bag. Insulate the vapor line thermister or TXV sensing bulb and vapor line with the provided pressure sensitive insulation (size 4” x 7” / 10.2 cm x 17.8 cm) and secure with provided wire ties.

IMPORTANT: Vapor line thermister or TXV sensing bulb should be located on a horizontal section of vapor line, just outside of coil box. The copper thermister must never be placed on any aluminum tube as this will result in galvanic corrosion and eventual failure of the aluminum tube.

IMPORTANT: Never place the thermister or sensing bulb on the heat effected zone near the braze connection, but it should be located within 6” [15.2 cm] of the indoor unit.

FIGURE 11A
THERMISTER LOCATION

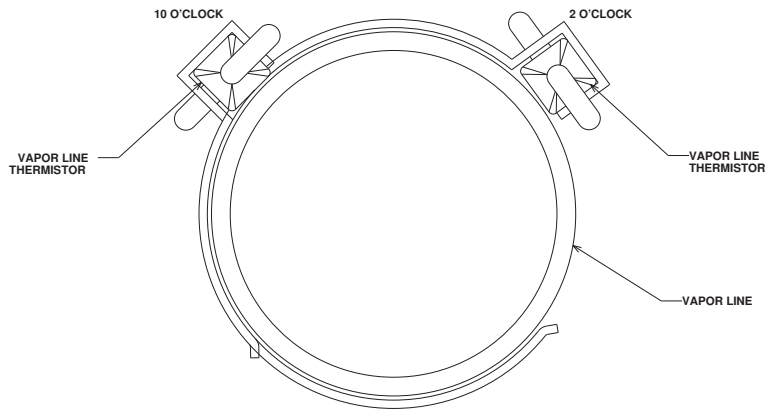

FIGURE 11B
TXV BULB LOCATION

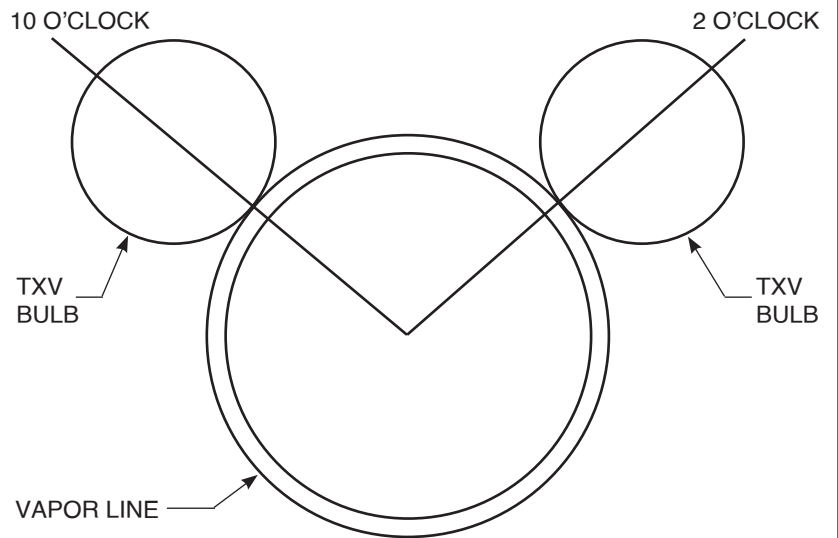

FIGURE 12A
THERMISTER LOCATION

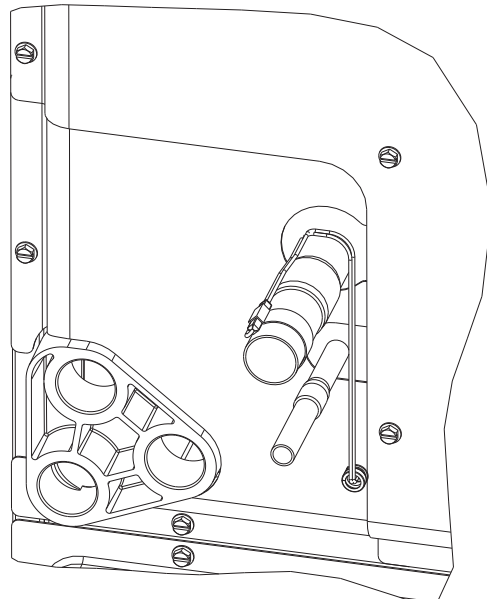
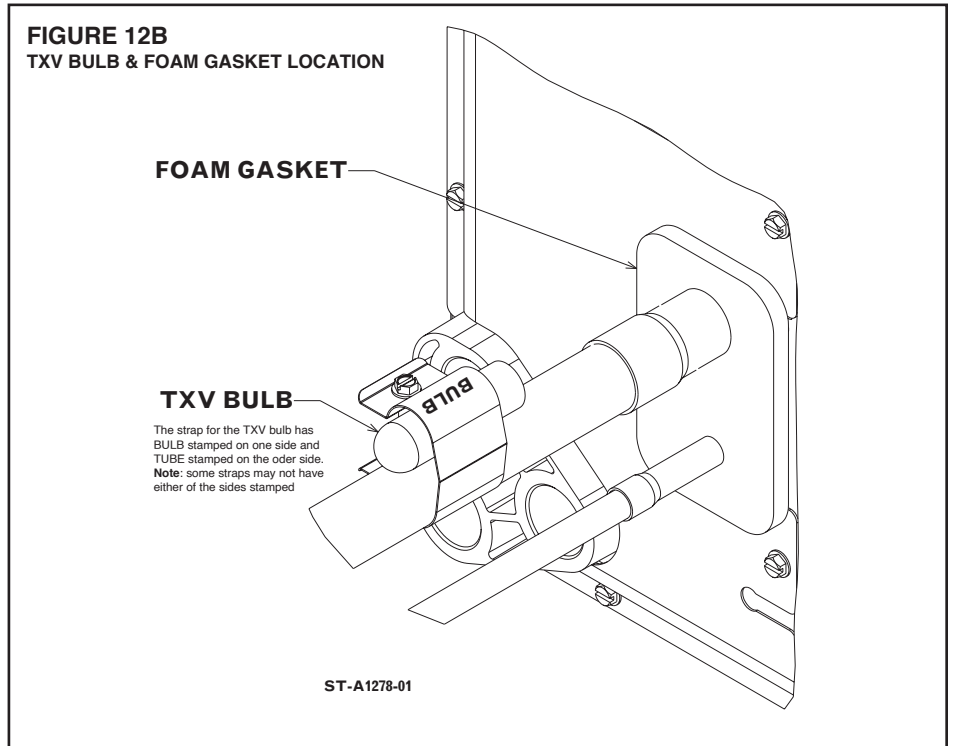

FIGURE 12B
TXV BULB & FOAM GASKET LOCATION



3.10 CONDENSATE DRAIN

Consult local codes or ordinances for specific requirements.

IMPORTANT: When making drain fitting connections to the drain pan, use a thin layer of Teflon paste, silicone or Teflon tape and install hand tight.

IMPORTANT: When making drain fitting connections to drain pan, do not overtighten. Overtightening fittings can split pipe connections on the drain pan.

- Install drain lines so they do not block service access to front of the unit. Minimum clearance of 24 inches [61 cm] is required for filter, coil or blower removal and service access.
- Although the condensate drain pan is designed is designed to be self draining, it is recommended that the air-handler cabinet be pitched slightly downward toward the primary drain connection to assure the condensate drains completely from the drain pan. The downward pitch should be approximately 1/8" per foot [10 mm per meter] and in both axes.
- Do not reduce drain line size less than connection size provided on condensate drain pan.
- All drain lines must be pitched downward away from the unit a minimum of 1/8" per foot [10 mm per meter] of line to ensure proper drainage.
- Do not connect condensate drain line to a closed or open sewer pipe. Run condensate to an open drain or outdoors.
- The drain line should be insulated where necessary to prevent sweating and damage due to condensate forming on the outside surface of the line.
- Make provisions for disconnecting and cleaning of the primary drain line should it become necessary. Install a 3 in. [7.62 cm] trap in the primary drain line as close to the unit as possible. Make sure that the top of the trap is below connection to the drain pan to allow complete drainage of pan (See Figure 13).
- The auxiliary drain line should be run to a place where it will be noticeable if it becomes operational. The building occupant should be warned that a problem exists if water should begin running from the auxiliary drain line. An auxiliary drain shut-off switch can be installed in lieu of an auxiliary drain line. The shut-off switch should be wired into the control circuit so the outdoor unit shuts down should the switch detect water.
- Plug the unused drain connection with the plugs provided in the parts bag, using a thin layer of teflon paste, silicone or teflon tape to form a water tight seal.
- Test the condensate drain pan and drain line after installation is complete. Pour water into drain pan, enough to fill drain trap and line. Check to make sure drain pan is draining completely, no leaks are found in drain line fittings, and water is draining from the open end of the primary drain line.

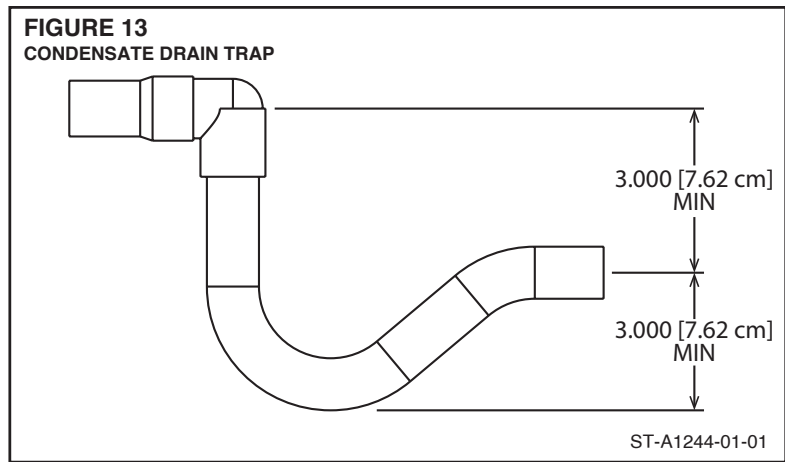

3.11 ECONET™ CONTROL CENTER OR THERMOSTAT

EcoNet™ CONTROL CENTER: All of the EcoNet™ enabled air-handlers covered in this manual are compatible with the communicating EcoNet™ Control Center. The EcoNet™ Control Center provides many benefits over a conventional 24VAC thermostat and is highly recommended to provide the necessary interface between the EcoNet™ enabled outdoor unit and the EcoNet™ enabled air-handler. When paired with an EcoNet™ enabled outdoor unit, the model data from the outdoor unit will be communicated to the EcoNet™ enabled (-)H2VZ, (-)H3VZ, or (-)HMVZ air-handler which automatically configures the air-handler to deliver the proper air-flow for that system. Other advantages are system status, advanced diagnostics, service tools, and custom adjustments available right at the Control Center as well as 4-wire connectivity, user friendly schedule programming, and internet connectivity using the WiFi module accessory. The EcoNet™ Control Center is required to enable variable speed air-flow in the (-)HMVZ air-handlers when matched to the variable speed (-)A18 and (-)P18 outdoor units.

CONVENTIONAL 24VAC THERMOSTAT: All of the air-handlers covered in this manual are capable of being controlled by a conventional 24VAC thermostat. For applications involving the variable speed (-)A18 and (-)P18 outdoor units, conventional 24VAC thermostats should only be used in emergency situations where operational problems are encountered using the EcoNet™ Control Center.

LOCATION: A EcoNet™ Control Center should be installed and wired according to the instructions provided with the Control Center and Section 3.12.7 of this manual. A 24VAC thermostat should be installed and wired according to the instructions provided with the thermostat and Sections 3.12.9 and 3.12.10 of this manual. The Control Center or thermostat should be mounted 4 – 5 feet [1.2 - 1.5 m] above the floor on an inside wall of the living room or hallway that has good air-circulation between all rooms being controlled so an average temperature for all rooms being controlled is being sensed. Movement of air should not be obstructed by furniture, doors, draperies, etc. The Control Center or thermostat should not be mounted where it will be affected by drafts, hot or cold water pipes or air ducts in walls, radiant heat from a fireplace, lamps, TV, or an outside wall.

3.12 ELECTRICAL WIRING

Field wiring must comply with the National Electric Code (C.E.C. in Canada) and any applicable local ordinance.

3.12.1 CONFIGURING UNIT FOR 208 VOLT POWER

The control transformer must be configured in the field to operate on a 208 volt electrical supply to assure adequate control voltage (24+ volts) with the reduced supply voltage. The units are shipped from the factory for 220-240 volt applications. For 208 volt applications, disconnect electrical power to the unit and remove the blower access panel and then the control box cover located on the blower housing. Then remove the insulated cap from the 208 volt transformer terminal and move the BLACK wires that are connected to the 240 volt transformer terminal to the 208 volt transformer terminal. Plug the insulated cap onto the transformer 240V terminal.

3.12.2 GROUNDING

- This product must be sufficiently grounded in accordance with National Electrical Code (C.E.C. in Canada) and any applicable local ordinance.
- Grounding may be accomplished by grounding metal conduit when installed in accordance with electrical codes to the unit cabinet.
- Grounding may also be accomplished by attaching ground wire(s) to ground lug(s) provided in the unit wiring compartment.

WARNING

The unit must be permanently grounded. Failure to do so can result in electrical shock causing personal injury or death.

- Ground lug(s) are located close to wire entrance on left side of unit (upflow). Lug(s) may be moved to marked locations near wire entrance on right side of unit (upflow), if alternate location is more convenient.
- Use of multiple supply circuits require grounding of each circuit to lug(s) provided in unit.

3.12.3 POWER WIRING

It is important that proper electrical power is available for connection to the unit model being installed. See the unit nameplate, wiring diagram and electrical data in the installation instructions.

- If required, install a branch circuit disconnect of adequate size, located within sight of, and readily accessible to the unit.
- **IMPORTANT:** Units with electric heater kits installed may be equipped with one, two, or three 30/60 amp circuit breakers. These breaker(s) protect the internal wiring in the event of a short circuit and serve as a disconnect. Circuit breakers installed within the unit do not provide over-current protection of the supply wiring and therefore may be sized larger than the branch circuit protection.
- Supply circuit power wiring must be 75°C minimum copper conductors only. See Electrical Data in Sections 3.12.5 and 3.12.6 for ampacity, wire size and circuit protector requirement. Supply circuit protective devices may be either fuses or "HACR" type circuit breakers.
- Field power wiring may be connected to either the right, left side or top. Three 7/8", 1^{3/32}", 1^{31/32}" [22.2 mm, 27.8 mm, 50.0 mm] dia. concentric knockouts are provided for connection of power wiring to unit.
- Field power wiring is to be connected to the power terminal block in unit control compartment.
- For units equipped with an electric heater kit, field power wiring is to be connected to the heater kit breaker, terminal block, or pullout disconnect terminals and the power wiring pigtail from the heater kit is to be connected to the unit power terminal block in the unit control compartment. Refer to installation instructions provided with the heater kit for additional details.

3.12.4 COPPER WIRE SIZE - AWG. (3% VOLTAGE DROP)

SUPPLY LENGTH	200 [61]	12	10	8	8	8	6	6	6	4	4	3	3	2	2	1	0	00
	150 [46]	12	10	10	10	8	8	6	6	6	4	4	3	3	2	1	0	00
	100 [30]	14	12	10	10	8	8	8	6	6	4	4	3	3	2	1	0	00
	50 [15]	14	12	10	10	8	8	8	6	6	4	4	3	3	2	1	0	00
		15	20	25	30	35	40	45	50	60	70	80	90	100	110	125	150	175
WIRE FEET	SUPPLY CIRCUIT AMPACITY																	
	NOTE: WIRE BASED ON COPPER CONDUCTORS 75°C MINIMUM RATING. FOR MORE THAN 3 CONDUCTORS IN A RACEWAY OR CABLE, SEE N.E.C. FOR DERATING THE AMPACITY OF EACH CONDUCTOR.																	

3.12.5 ELECTRICAL DATA - BLOWER MOTOR ONLY - WITHOUT ELECTRIC HEAT: (-)H2VZ/ (-)H3VZ/(-)HMVZ

Model Family	Model Size	Voltage	Phase*	Hertz	HP	RPM	Circuit Amps	Minimum Circuit Ampacity	Maximum Overcurrent Ampacity
(-)H2VZ	2417STANN	208/240	1	60	1/3	300-1300	2.8	4	15
	3617STANN		1		1/2		4.6	6	15
	3621STANN		1		1/3		2.7	4	15
	3621MTANN		1		1/2		3.9	5	15
	3621MTANA		1		1/2		3.8	5	15
	4821STANN		1		3/4		5.4	7	15
	4821STANA		1		3/4		5.7	8	15
	4824STANN		1		3/4		5.1	7	15
	6021STANA		1		3/4		5.7	8	15
	6024STANN		1		3/4		5.2	7	15
(-)H3VZ	2417STA(-)N	208/240	1	60	1/3	300-1300	2.8	4	15
	2417MTA(-)N		1		1/2		4.6	6	15
	3617STA(-)N		1		1/2		4.6	6	15
	3621MTA(-)N		1		3/4		5.4	7	15
	4821STA(-)N		1		3/4		5.4	7	15
	4824STA(-)N		1		3/4		5.2	7	15
	6024STA(-)N		1		3/4		5.2	7	15
(-)HMVZ	2417SEACN	208/240	1	60	1/3	300-1300	2.8	4	15
	2421MEACN		1		1/3		2.7	4	15
	2421HEACN		1		1/2		3.5	5	15
	2421HEACA		1		3/4		5.7	8	15
	6021SEACA		1		3/4		5.7	8	15
	6024SEACN		1		3/4		5.2	7	15

*Blower motors are all single-phase motors

3.12.5.1 ELECTRICAL DATA - WITH ELECTRIC HEAT: (-)H2VZ

Installation of the UL Listed original equipment manufacturer provided heater kits listed in the following table is recommended for all auxiliary heating requirements.

Air Handler Model	Heater Model Number	Heater kW (208/240V)	Ph/Hz	No. Elements - kW per	Circuit Type	Heater Circuit Amps	Tested Blower Motor Amps	Minimum Circuit Ampacity	Maximum Overcurrent Protection
(-)H2VZ2417STANNJ	RXBH-1724?03J-B	2.3/3.0	1/60	1-3.0	SINGLE	11.1/12.5	2.8	18/20	20/20
	RXBH-1724?05J-B	3.6/4.8	1/60	1-4.8	SINGLE	17.4/20	2.8	26/29	30/30
	RXBH-1724?07J-B	5.4/7.2	1/60	2-3.6	SINGLE	26/30	2.8	36/41	40/45
	RXBH-1724?10J-B	7.2/9.6	1/60	2-4.8	SINGLE	34.7/40	2.8	47/54	50/60
	RXBH-1724A13J-B	9.4/12.5	1/60	3-4.17	SINGLE	45.2/52.1	2.8	60/69	60/70
		3.1/4.2	1/60	1-4.17	MULTIPLE CKT 1	15/17.5	2.8	23/26	25/30
		6.3/8.3	1/60	2-4.17	MULTIPLE CKT 2	30.3/34.6	0	38/44	40/45
	RXBH-17A05C-B	3.6/4.8	3/60	1-4.8	SINGLE	10/11.6	2.8	16/18	20/20
	RXBH-24A05C-B	3.6/4.8	3/60	1-4.8	SINGLE	10/11.6	2.8	16/18	20/20
	RXBH-1724B05C-B	3.6/4.8	3/60	1-4.8	SINGLE	10/11.6	2.8	16/18	20/20
	RXBH-1724A07C-B	5.4/7.2	3/60	2-3.6	SINGLE	15/17.4	2.8	23/26	25/30
	RXBH-1724A10C-B	7.2/9.6	3/60	2-4.8	SINGLE	20/23.1	2.8	29/33	30/35
RXBH-1724A13C-B	9.4/12.5	3/60	3-4.17	SINGLE	26.1/30.1	2.8	37/42	40/45	

? Heater Kit Connection Type A=Breaker B=Terminal Block C=Pullout Disconnect

3.12.5.1 ELECTRICAL DATA - WITH ELECTRIC HEAT: (-)H2VZ - continued

Air Handler Model	Heater Model Number	Heater kW (208/240V)	Ph/Hz	No. Elements - kW per	Circuit Type	Heater Circuit Amps	Tested Blower Motor Amps	Minimum Circuit Ampacity	Maximum Overcurrent Protection
(-)H2VZ3617STANNJ	RXBH-1724?03J-B	2.3/3.0	1/60	1-3.0	SINGLE	11.1/12.5	4.6	20/22	20/25
	RXBH-1724?05J-B	3.6/4.8	1/60	1-4.8	SINGLE	17.4/20	4.6	28/31	30/35
	RXBH-1724?07J-B	5.4/7.2	1/60	2-3.6	SINGLE	26/30	4.6	39/44	40/45
	RXBH-1724?10J-B	7.2/9.6	1/60	2-4.8	SINGLE	34.7/40	4.6	50/56	50/60
	RXBH-1724A13J-B	9.4/12.5	1/60	3-4.17	SINGLE	45.2/52.1	4.6	63/71	70/80
		3.1/4.2	1/60	1-4.17	MULTIPLE CKT 1	15/17.5	4.6	25/28	25/30
		6.3/8.3	1/60	2-4.17	MULTIPLE CKT 2	30.3/34.6	0	38/44	40/45
	RXBH-1724A15J-B	10.8/14.4	1/60	3-4.8	SINGLE	52/60	4.6	71/81	80/90
		3.6/4.8	1/60	1-4.8	MULTIPLE CKT 1	17.4/20	4.6	28/31	30/35
		7.2/9.6	1/60	2-4.8	MULTIPLE CKT 2	34.7/40	0	44/50	45/50
	RXBH-1724A18J-B	12.8/17.0	1/60	3-5.68	SINGLE	61.6/70.9	4.6	83/95	90/100
		4.3/5.7	1/60	1-5.68	MULTIPLE CKT 1	20.7/23.8	4.6	32/36	35/40
		8.5/11.3	1/60	2-5.68	MULTIPLE CKT 2	40.9/47.1	0	52/59	60/60
	RXBH-17A05C-B	3.6/4.8	3/60	1-4.8	SINGLE	10/11.6	4.6	19/21	20/25
	RXBH-24A05C-B	3.6/4.8	3/60	1-4.8	SINGLE	10/11.6	4.6	19/21	20/25
	RXBH-1724B05C-B	3.6/4.8	3/60	1-4.8	SINGLE	10/11.6	4.6	19/21	20/25
	RXBH-1724A07C-B	5.4/7.2	3/60	2-3.6	SINGLE	15/17.4	4.6	25/28	25/30
	RXBH-1724A10C-B	7.2/9.6	3/60	2-4.8	SINGLE	20/23.1	4.6	31/35	35/35
RXBH-1724A13C-B	9.4/12.5	3/60	3-4.17	SINGLE	26.1/30.1	4.6	39/44	40/45	
RXBH-1724A15C-B	10.8/14.4	3/60	3-4.8	SINGLE	30/34.7	4.6	44/50	45/50	
RXBH-1724A18C-B	12.8/17.0	3/60	3-5.68	SINGLE	35.6/40.9	4.6	51/57	60/60	
(-)H2VZ3621STANNJ	RXBH-1724?03J-B	2.3/3.0	1-3.0	1-3.0	SINGLE	11.1/12.5	2.7	18/19	20/20
	RXBH-1724?05J-B	3.6/4.8	1-4.8	1-4.8	SINGLE	17.4/20	2.7	26/29	30/30
	RXBH-1724?07J-B	5.4/7.2	2-3.6	2-3.6	SINGLE	26/30	2.7	36/41	40/45
	RXBH-1724?10J-B	7.2/9.6	2-4.8	2-4.8	SINGLE	34.7/40	2.7	47/54	50/60
	RXBH-1724A13J-B	9.4/12.5	3-4.17	3-4.17	SINGLE	45.2/52.1	2.7	60/69	60/70
		3.1/4.2	1-4.17	1-4.17	MULTIPLE CKT 1	15/17.5	2.7	23/26	25/30
		6.3/8.3	2-4.17	2-4.17	MULTIPLE CKT 2	30.3/34.6	0	38/44	40/45
	RXBH-1724A15J-B	10.8/14.4	3-4.8	3-4.8	SINGLE	52/60	2.7	69/79	70/80
		3.6/4.8	1-4.8	1-4.8	MULTIPLE CKT 1	17.4/20	2.7	26/29	30/30
		7.2/9.6	2-4.8	2-4.8	MULTIPLE CKT 2	34.7/40	0	44/50	45/50
	RXBH-1724A18J-B	12.8/17.0	3-5.68	3-5.68	SINGLE	61.6/70.9	2.7	81/92	90/100
		4.3/5.7	1-5.68	1-5.68	MULTIPLE CKT 1	20.7/23.8	2.7	30/34	30/35
		8.5/11.3	2-5.68	2-5.68	MULTIPLE CKT 2	40.9/47.1	0	52/59	60/60
	RXBH-17A05C-B	3.6/4.8	3/60	1-4.8	SINGLE	10/11.6	2.7	16/18	20/20
	RXBH-24A05C-B	3.6/4.8	3/60	1-4.8	SINGLE	10/11.6	2.7	16/18	20/20
	RXBH-1724B05C-B	3.6/4.8	3/60	1-4.8	SINGLE	10/11.6	2.7	16/18	20/20
	RXBH-1724A07C-B	5.4/7.2	3/60	2-3.6	SINGLE	15/17.4	2.7	23/26	25/30
	RXBH-1724A10C-B	7.2/9.6	3/60	2-4.8	SINGLE	20/23.1	2.7	29/33	30/35
RXBH-1724A13C-B	9.4/12.5	3/60	3-4.17	SINGLE	26.1/30.1	2.7	36/41	40/45	
RXBH-1724A15C-B	10.8/14.4	3/60	3-4.8	SINGLE	30/34.7	2.7	41/47	45/50	
RXBH-1724A18C-B	12.8/17.0	3/60	3-5.68	SINGLE	35.6/40.9	2.7	48/55	50/60	

? Heater Kit Connection Type A=Breaker B=Terminal Block C=Pullout Disconnect

3.12.5.1 ELECTRICAL DATA - WITH ELECTRIC HEAT: (-)H2VZ - continued

Air Handler Model	Heater Model Number	Heater kW (208/240V)	Ph/Hz	No. Elements - kW per	Circuit Type	Heater Circuit Amps	Tested Blower Motor Amps	Minimum Circuit Ampacity	Maximum Overcurrent Protection
(-)H2VZ3621MTANNJ	RXBH-1724?03J-B	2.3/3.0	1/60	1-3.0	SINGLE	11.1/12.5	3.9	19/21	20/25
	RXBH-1724?05J-B	3.6/4.8	1/60	1-4.8	SINGLE	17.4/20	3.9	27/30	30/30
	RXBH-1724?07J-B	5.4/7.2	1/60	2-3.6	SINGLE	26/30	3.9	38/43	40/45
	RXBH-1724?10J-B	7.2/9.6	1/60	2-4.8	SINGLE	34.7/40	3.9	49/55	50/60
	RXBH-1724A13J-B	9.4/12.5	1/60	3-4.17	SINGLE	45.2/52.1	3.9	62/70	70/70
		3.1/4.2	1/60	1-4.17	MULTIPLE CKT 1	15/17.5	3.9	24/27	25/30
		6.3/8.3	1/60	2-4.17	MULTIPLE CKT 2	30.3/34.6	0	38/44	40/45
	RXBH-1724A15J-B	10.8/14.4	1/60	3-4.8	SINGLE	52/60	3.9	70/80	70/80
		3.6/4.8	1/60	1-4.8	MULTIPLE CKT 1	17.4/20	3.9	27/30	30/30
		7.2/9.6	1/60	2-4.8	MULTIPLE CKT 2	34.7/40	0	44/50	45/50
	RXBH-1724A18J-B	12.8/17.0	1/60	3-5.68	SINGLE	61.6/70.9	3.9	82/94	90/100
		4.3/5.7	1/60	1-5.68	MULTIPLE CKT 1	20.7/23.8	3.9	31/35	35/35
		8.5/11.3	1/60	2-5.68	MULTIPLE CKT 2	40.9/47.1	0	52/59	60/60
	RXBH-17A05C-B	3.6/4.8	3/60	1-4.8	SINGLE	10/11.6	3.9	18/20	20/20
	RXBH-24A05C-B	3.6/4.8	3/60	1-4.8	SINGLE	10/11.6	3.9	18/20	20/20
	RXBH-1724B05C-B	3.6/4.8	3/60	1-4.8	SINGLE	10/11.6	3.9	18/20	20/20
	RXBH-1724A07C-B	5.4/7.2	3/60	2-3.6	SINGLE	15/17.4	3.9	24/27	25/30
	RXBH-1724A10C-B	7.2/9.6	3/60	2-4.8	SINGLE	20/23.1	3.9	30/34	30/35
	RXBH-1724A13C-B	9.4/12.5	3/60	3-4.17	SINGLE	26.1/30.1	3.9	38/43	40/45
	RXBH-1724A15C-B	10.8/14.4	3/60	3-4.8	SINGLE	30/34.7	3.9	43/49	45/50
RXBH-1724A18C-B	12.8/17.0	3/60	3-5.68	SINGLE	35.6/40.9	3.9	50/56	50/60	
(-)H2VZ3621MTANAJ	RXBH-1724?03J-B	2.3/3.0	1/60	1-3.0	SINGLE	11.1/12.5	3.8	20/25	19/21
	RXBH-1724?05J-B	3.6/4.8	1/60	1-4.8	SINGLE	17.4/20	3.8	30/30	27/30
	RXBH-1724?07J-B	5.4/7.2	1/60	2-3.6	SINGLE	26/30	3.8	40/45	38/43
	RXBH-1724?10J-B	7.2/9.6	1/60	2-4.8	SINGLE	34.7/40	3.8	50/60	49/55
	RXBH-1724A13J-B	9.4/12.5	1/60	3-4.17	SINGLE	45.2/52.1	3.8	70/70	62/70
		3.1/4.2	1/60	1-4.17	MULTIPLE CKT 1	15/17.5	3.8	25/30	24/27
		6.3/8.3	1/60	2-4.17	MULTIPLE CKT 2	30.3/34.6	0	40/45	38/44
	RXBH-1724A15J-B	10.8/14.4	1/60	3-4.8	SINGLE	52/60	3.8	70/80	70/80
		3.6/4.8	1/60	1-4.8	MULTIPLE CKT 1	17.4/20	3.8	30/30	27/30
		7.2/9.6	1/60	2-4.8	MULTIPLE CKT 2	34.7/40	0	45/50	44/50
	RXBH-1724A18J-B	12.8/17.0	1/60	3-5.68	SINGLE	61.6/70.9	3.8	90/100	82/94
		4.3/5.7	1/60	1-5.68	MULTIPLE CKT 1	20.7/23.8	3.8	35/35	31/35
		8.5/11.3	1/60	2-5.68	MULTIPLE CKT 2	40.9/47.1	0	60/60	52/59
	RXBH-17A05C-B	3.6/4.8	3/60	1-4.8	SINGLE	10/11.6	3.8	18/20	20/20
	RXBH-24A05C-B	3.6/4.8	3/60	1-4.8	SINGLE	10/11.6	3.8	18/20	20/20
	RXBH-1724B05C-B	3.6/4.8	3/60	1-4.8	SINGLE	10/11.6	3.8	18/20	20/20
	RXBH-1724A07C-B	5.4/7.2	3/60	2-3.6	SINGLE	15/17.4	3.8	24/27	25/30
	RXBH-1724A10C-B	7.2/9.6	3/60	2-4.8	SINGLE	20/23.1	3.8	30/34	30/35
	RXBH-1724A13C-B	9.4/12.5	3/60	3-4.17	SINGLE	26.1/30.1	3.8	38/43	40/45
	RXBH-1724A15C-B	10.8/14.4	3/60	3-4.8	SINGLE	30/34.7	3.8	43/49	45/50
RXBH-1724A18C-B	12.8/17.0	3/60	3-5.68	SINGLE	35.6/40.9	3.8	50/56	50/60	

? Heater Kit Connection Type A = Breaker B = Terminal Block C = Pullout Disconnect

3.12.5.1 ELECTRICAL DATA - WITH ELECTRIC HEAT: (-)H2VZ - continued

Air Handler Model	Heater Model Number	Heater kW (208/240V)	Ph/Hz	No. Elements - kW per	Circuit Type	Heater Circuit Amps	Tested Blower Motor Amps	Minimum Circuit Ampacity	Maximum Overcurrent Protection
(-)H2VZ4821STANNJ	RXBH-1724?03J-B	2.3/3.0	1/60	1-3.0	SINGLE	11.1/12.5	5.4	21/23	25/25
	RXBH-1724?05J-B	3.6/4.8	1/60	1-4.8	SINGLE	17.4/20	5.4	29/32	30/35
	RXBH-1724?07J-B	5.4/7.2	1/60	2-3.6	SINGLE	26/30	5.4	40/45	40/45
	RXBH-1724?10J-B	7.2/9.6	1/60	2-4.8	SINGLE	34.7/40	5.4	51/57	60/60
	RXBH-1724A13J-B	9.4/12.5	1/60	3-4.17	SINGLE	45.2/52.1	5.4	64/72	70/80
		3.1/4.2	1/60	1-4.17	MULTIPLE CKT 1	15/17.5	5.4	26/29	30/30
		6.3/8.3	1/60	2-4.17	MULTIPLE CKT 2	30.3/34.6	0	38/44	40/45
	RXBH-1724A15J-B	10.8/14.4	1/60	3-4.8	SINGLE	52/60	5.4	72/82	80/90
		3.6/4.8	1/60	1-4.8	MULTIPLE CKT 1	17.4/20	5.4	29/32	30/35
		7.2/9.6	1/60	2-4.8	MULTIPLE CKT 2	34.7/40	0	44/50	45/50
	RXBH-1724A18J-B	12.8/17.0	1/60	3-5.68	SINGLE	61.6/70.9	5.4	84/96	90/100
		4.3/5.7	1/60	1-5.68	MULTIPLE CKT 1	20.7/23.8	5.4	33/37	35/40
		8.5/11.3	1/60	2-5.68	MULTIPLE CKT 2	40.9/47.1	0	52/59	60/60
	RXBH-24A20J-B	14.4/19.2	1/60	4-4.8	SINGLE	69.3/80	5.4	94/107	100/110
		7.2/9.6	1/60	2-4.8	MULTIPLE CKT 1	34.7/40	5.4	51/57	60/60
		7.2/9.6	1/60	2-4.8	MULTIPLE CKT 2	34.7/40	0	44/50	45/50
	RXBH-24A25J-B	18.0/24.0	1/60	6-4.0	SINGLE	86.6/100	5.4	115/132	125/150
		6.0/8.0	1/60	2-4.0	MULTIPLE CKT 1	28.9/33.4	5.4	43/49	45/50
		6.0/8.0	1/60	2-4.0	MULTIPLE CKT 2	28.9/33.4	0	37/42	40/45
		6.0/8.0	1/60	2-4.0	MULTIPLE CKT 3	28.9/33.4	0	37/42	40/45
	RXBH-24A30J-B	21.6/28.8	1/60	6-4.8	SINGLE	103.9/120	5.4	137/157	150/175
		7.2/9.6	1/60	2-4.8	MULTIPLE CKT 1	34.7/40	5.4	51/57	60/60
		7.2/9.6	1/60	2-4.8	MULTIPLE CKT 2	34.7/40	0	44/50	45/50
		7.2/9.6	1/60	2-4.8	MULTIPLE CKT 3	34.7/40	0	44/50	45/50
	RXBH-17A05C-B	3.6/4.8	3/60	1-4.8	SINGLE	10/11.6	5.4	20/22	20/25
	RXBH-24A05C-B	3.6/4.8	3/60	1-4.8	SINGLE	10/11.6	5.4	20/22	20/25
	RXBH-1724B05C-B	3.6/4.8	3/60	1-4.8	SINGLE	10/11.6	5.4	20/22	20/25
	RXBH-1724A07C-B	5.4/7.2	3/60	2-3.6	SINGLE	15/17.4	5.4	26/29	30/30
	RXBH-1724A10C-B	7.2/9.6	3/60	2-4.8	SINGLE	20/23.1	5.4	32/36	35/40
	RXBH-1724A13C-B	9.4/12.5	3/60	3-4.17	SINGLE	26.1/30.1	5.4	40/45	40/45
	RXBH-1724A15C-B	10.8/14.4	3/60	3-4.8	SINGLE	30/34.7	5.4	45/51	45/60
	RXBH-1724A18C-B	12.8/17.0	3/60	3-5.68	SINGLE	35.6/40.9	5.4	52/58	60/60
	RXBH-24A20C-B	14.4/19.2	3/60	4-4.8	SINGLE	40/46.2	5.4	57/65	60/70
		7.2/9.6	3/60	2-4.8	MULTIPLE CKT 1	20/23.1	5.4	32/36	35/40
		7.2/9.6	3/60	2-4.8	MULTIPLE CKT 2	20/23.1	0	25/29	25/30
	RXBH-24A25C-B	18.0/24.0	3/60	6-4.0	SINGLE	50/57.7	5.4	70/79	70/80
		9.0/12.0	3/60	3-4.0	MULTIPLE CKT 1	25/28.9	5.4	38/43	40/45
		9.0/12.0	3/60	3-4.0	MULTIPLE CKT 2	25/28.9	0	32/37	35/40
	RXBH-24A30C-B	21.6/28.8	3/60	6-4.8	SINGLE	60/69.3	5.4	82/94	90/100
		10.8/14.4	3/60	3-4.8	MULTIPLE CKT 1	30/34.7	5.4	45/51	45/60
10.8/14.4		3/60	3-4.8	MULTIPLE CKT 2	30/34.7	0	38/44	40/45	

? Heater Kit Connection Type A = Breaker B = Terminal Block C = Pullout Disconnect

3.12.5.1 ELECTRICAL DATA - WITH ELECTRIC HEAT: (-)H2VZ - continued

Air Handler Model	Heater Model Number	Heater kW (208/240V)	Ph/Hz	No. Elements - kW per	Circuit Type	Heater Circuit Amps	Tested Blower Motor Amps	Minimum Circuit Ampacity	Maximum Overcurrent Protection
(-)H2VZ4821STANAJ	RXBH-1724?03J-B	2.3/3.0	1/60	1-3.0	SINGLE	11.1/12.5	5.7	21/23	25/25
	RXBH-1724?05J-B	3.6/4.8	1/60	1-4.8	SINGLE	17.4/20	5.7	29/33	30/35
	RXBH-1724?07J-B	5.4/7.2	1/60	2-3.6	SINGLE	26/30	5.7	40/45	40/45
	RXBH-1724?10J-B	7.2/9.6	1/60	2-4.8	SINGLE	34.7/40	5.7	51/58	60/60
	RXBH-1724A13J-B	9.4/12.5	1/60	3-4.17	SINGLE	45.2/52.1	5.7	64/73	70/80
		3.1/4.2	1/60	1-4.17	MULTIPLE CKT 1	15/17.5	5.7	26/29	30/30
		6.3/8.3	1/60	2-4.17	MULTIPLE CKT 2	30.3/34.6	0	38/44	40/45
	RXBH-1724A15J-B	10.8/14.4	1/60	3-4.8	SINGLE	52/60	5.7	73/83	80/90
		3.6/4.8	1/60	1-4.8	MULTIPLE CKT 1	17.4/20	5.7	29/33	30/35
		7.2/9.6	1/60	2-4.8	MULTIPLE CKT 2	34.7/40	0	44/50	45/50
	RXBH-1724A18J-B	12.8/17.0	1/60	3-5.68	SINGLE	61.6/70.9	5.7	85/96	90/100
		4.3/5.7	1/60	1-5.68	MULTIPLE CKT 1	20.7/23.8	5.7	33/37	35/40
		8.5/11.3	1/60	2-5.68	MULTIPLE CKT 2	40.9/47.1	0	52/59	60/60
	RXBH-24A20J-B	14.4/19.2	1/60	4-4.8	SINGLE	69.3/80	5.7	94/108	100/110
		7.2/9.6	1/60	2-4.8	MULTIPLE CKT 1	34.7/40	5.7	51/58	60/60
		7.2/9.6	1/60	2-4.8	MULTIPLE CKT 2	34.7/40	0	44/50	45/50
	RXBH-24A25J-B	18.0/24.0	1/60	6-4.0	SINGLE	86.6/100	5.7	116/133	125/150
		6.0/8.0	1/60	2-4.0	MULTIPLE CKT 1	28.9/33.4	5.7	44/49	45/50
		6.0/8.0	1/60	2-4.0	MULTIPLE CKT 2	28.9/33.4	0	37/42	40/45
		6.0/8.0	1/60	2-4.0	MULTIPLE CKT 3	28.9/33.4	0	37/42	40/45
	RXBH-24A30J-B	21.6/28.8	1/60	6-4.8	SINGLE	103.9/120	5.7	137/158	150/175
		7.2/9.6	1/60	2-4.8	MULTIPLE CKT 1	34.7/40	5.7	51/58	60/60
		7.2/9.6	1/60	2-4.8	MULTIPLE CKT 2	34.7/40	0	44/50	45/50
		7.2/9.6	1/60	2-4.8	MULTIPLE CKT 3	34.7/40	0	44/50	45/50
	RXBH-17A05C-B	3.6/4.8	3/60	1-4.8	SINGLE	10/11.6	5.7	20/22	20/25
	RXBH-24A05C-B	3.6/4.8	3/60	1-4.8	SINGLE	10/11.6	5.7	20/22	20/25
	RXBH-1724B05C-B	3.6/4.8	3/60	1-4.8	SINGLE	10/11.6	5.7	20/22	20/25
	RXBH-1724A07C-B	5.4/7.2	3/60	2-3.6	SINGLE	15/17.4	5.7	26/29	30/30
	RXBH-1724A10C-B	7.2/9.6	3/60	2-4.8	SINGLE	20/23.1	5.7	33/36	35/40
	RXBH-1724A13C-B	9.4/12.5	3/60	3-4.17	SINGLE	26.1/30.1	5.7	40/45	40/45
	RXBH-1724A15C-B	10.8/14.4	3/60	3-4.8	SINGLE	30/34.7	5.7	45/51	45/60
	RXBH-1724A18C-B	12.8/17.0	3/60	3-5.68	SINGLE	35.6/40.9	5.7	52/59	60/60
	RXBH-24A20C-B	14.4/19.2	3/60	4-4.8	SINGLE	40/46.2	5.7	58/65	60/70
		7.2/9.6	3/60	2-4.8	MULTIPLE CKT 1	20/23.1	5.7	33/36	35/40
		7.2/9.6	3/60	2-4.8	MULTIPLE CKT 2	20/23.1	0	25/29	25/30
	RXBH-24A25C-B	18.0/24.0	3/60	6-4.0	SINGLE	50/57.7	5.7	70/80	70/80
		9.0/12.0	3/60	3-4.0	MULTIPLE CKT 1	25/28.9	5.7	39/44	40/45
		9.0/12.0	3/60	3-4.0	MULTIPLE CKT 2	25/28.9	0	32/37	35/40
	RXBH-24A30C-B	21.6/28.8	3/60	6-4.8	SINGLE	60/69.3	5.7	83/94	90/100
		10.8/14.4	3/60	3-4.8	MULTIPLE CKT 1	30/34.7	5.7	45/51	45/60
		10.8/14.4	3/60	3-4.8	MULTIPLE CKT 2	30/34.7	0	38/44	40/45

? Heater Kit Connection Type A = Breaker B = Terminal Block C = Pullout Disconnect

3.12.5.1 ELECTRICAL DATA - WITH ELECTRIC HEAT: (-)H2VZ - continued

Air Handler Model	Heater Model Number	Heater kW (208/240V)	Ph/Hz	No. Elements - kW per	Circuit Type	Heater Circuit Amps	Tested Blower Motor Amps	Minimum Circuit Ampacity	Maximum Overcurrent Protection
(-)H2VZ4824STANNJ	RXBH-1724?03J-B	2.3/3.0	1/60	1-3.0	SINGLE	11.1/12.5	5.1	21/22	25/25
	RXBH-1724?05J-B	3.6/4.8	1/60	1-4.8	SINGLE	17.4/20	5.1	29/32	30/35
	RXBH-1724?07J-B	5.4/7.2	1/60	2-3.6	SINGLE	26/30	5.1	39/44	40/45
	RXBH-1724?10J-B	7.2/9.6	1/60	2-4.8	SINGLE	34.7/40	5.1	50/57	50/60
	RXBH-1724A13J-B	9.4/12.5	1/60	3-4.17	SINGLE	45.2/52.1	5.1	63/72	70/80
		3.1/4.2	1/60	1-4.17	MULTIPLE CKT 1	15/17.5	5.1	26/29	30/30
		6.3/8.3	1/60	2-4.17	MULTIPLE CKT 2	30.3/34.6	0	38/44	40/45
	RXBH-1724A15J-B	10.8/14.4	1/60	3-4.8	SINGLE	52/60	5.1	72/82	80/90
		3.6/4.8	1/60	1-4.8	MULTIPLE CKT 1	17.4/20	5.1	29/32	30/35
		7.2/9.6	1/60	2-4.8	MULTIPLE CKT 2	34.7/40	0	44/50	45/50
	RXBH-1724A18J-B	12.8/17.0	1/60	3-5.68	SINGLE	61.6/70.9	5.1	84/95	90/100
		4.3/5.7	1/60	1-5.68	MULTIPLE CKT 1	20.7/23.8	5.1	33/37	35/40
		8.5/11.3	1/60	2-5.68	MULTIPLE CKT 2	40.9/47.1	0	52/59	60/60
	RXBH-24A20J-B	14.4/19.2	1/60	4-4.8	SINGLE	69.3/80	5.1	93/107	100/110
		7.2/9.6	1/60	2-4.8	MULTIPLE CKT 1	34.7/40	5.1	50/57	50/60
		7.2/9.6	1/60	2-4.8	MULTIPLE CKT 2	34.7/40	0	44/50	45/50
	RXBH-24A25J-B	18.0/24.0	1/60	6-4.0	SINGLE	86.6/100	5.1	115/132	125/150
		6.0/8.0	1/60	2-4.0	MULTIPLE CKT 1	28.9/33.4	5.1	43/49	45/50
		6.0/8.0	1/60	2-4.0	MULTIPLE CKT 2	28.9/33.4	0	37/42	40/45
		6.0/8.0	1/60	2-4.0	MULTIPLE CKT 3	28.9/33.4	0	37/42	40/45
	RXBH-24A30J-B	21.6/28.8	1/60	6-4.8	SINGLE	103.9/120	5.1	137/157	150/175
		7.2/9.6	1/60	2-4.8	MULTIPLE CKT 1	34.7/40	5.1	50/57	50/60
		7.2/9.6	1/60	2-4.8	MULTIPLE CKT 2	34.7/40	0	44/50	45/50
		7.2/9.6	1/60	2-4.8	MULTIPLE CKT 3	34.7/40	0	44/50	45/50
	RXBH-17A05C-B	3.6/4.8	3/60	1-4.8	SINGLE	10/11.6	5.1	19/21	20/25
	RXBH-24A05C-B	3.6/4.8	3/60	1-4.8	SINGLE	10/11.6	5.1	19/21	20/25
	RXBH-1724B05C-B	3.6/4.8	3/60	1-4.8	SINGLE	10/11.6	5.1	19/21	20/25
	RXBH-1724A07C-B	5.4/7.2	3/60	2-3.6	SINGLE	15/17.4	5.1	26/29	30/30
	RXBH-1724A10C-B	7.2/9.6	3/60	2-4.8	SINGLE	20/23.1	5.1	32/36	35/40
	RXBH-1724A13C-B	9.4/12.5	3/60	3-4.17	SINGLE	26.1/30.1	5.1	39/44	40/45
	RXBH-1724A15C-B	10.8/14.4	3/60	3-4.8	SINGLE	30/34.7	5.1	44/50	45/50
	RXBH-1724A18C-B	12.8/17.0	3/60	3-5.68	SINGLE	35.6/40.9	5.1	51/58	60/60
	RXBH-24A20C-B	14.4/19.2	3/60	4-4.8	SINGLE	40/46.2	5.1	57/65	60/70
		7.2/9.6	3/60	2-4.8	MULTIPLE CKT 1	20/23.1	5.1	32/36	35/40
		7.2/9.6	3/60	2-4.8	MULTIPLE CKT 2	20/23.1	0	25/29	25/30
	RXBH-24A25C-B	18.0/24.0	3/60	6-4.0	SINGLE	50/57.7	5.1	69/79	70/80
		9.0/12.0	3/60	3-4.0	MULTIPLE CKT 1	25/28.9	5.1	38/43	40/45
		9.0/12.0	3/60	3-4.0	MULTIPLE CKT 2	25/28.9	0	32/37	35/40
	RXBH-24A30C-B	21.6/28.8	3/60	6-4.8	SINGLE	60/69.3	5.1	82/93	90/100
		10.8/14.4	3/60	3-4.8	MULTIPLE CKT 1	30/34.7	5.1	44/50	45/50
10.8/14.4		3/60	3-4.8	MULTIPLE CKT 2	30/34.7	0	38/44	40/45	

? Heater Kit Connection Type A = Breaker B = Terminal Block C = Pullout Disconnect

3.12.5.1 ELECTRICAL DATA - WITH ELECTRIC HEAT: (-)H2VZ - continued

Air Handler Model	Heater Model Number	Heater kW (208/240V)	Ph/Hz	No. Elements - kW per	Circuit Type	Heater Circuit Amps	Tested Blower Motor Amps	Minimum Circuit Ampacity	Maximum Overcurrent Protection
(-)H2VZ6021STANAJ	RXBH-1724?03J-B	2.3/3.0	1/60	1-3.0	SINGLE	11.1/12.5	5.7	21/23	25/25
	RXBH-1724?05J-B	3.6/4.8	1/60	1-4.8	SINGLE	17.4/20	5.7	29/33	30/35
	RXBH-1724?07J-B	5.4/7.2	1/60	2-3.6	SINGLE	26/30	5.7	40/45	40/45
	RXBH-1724?10J-B	7.2/9.6	1/60	2-4.8	SINGLE	34.7/40	5.7	51/58	60/60
	RXBH-1724A13J-B	9.4/12.5	1/60	3-4.17	SINGLE	45.2/52.1	5.7	64/73	70/80
		3.1/4.2	1/60	1-4.17	MULTIPLE CKT 1	15/17.5	5.7	26/29	30/30
		6.3/8.3	1/60	2-4.17	MULTIPLE CKT 2	30.3/34.6	0	38/44	40/45
	RXBH-1724A15J-B	10.8/14.4	1/60	3-4.8	SINGLE	52/60	5.7	73/83	80/90
		3.6/4.8	1/60	1-4.8	MULTIPLE CKT 1	17.4/20	5.7	29/33	30/35
		7.2/9.6	1/60	2-4.8	MULTIPLE CKT 2	34.7/40	0	44/50	45/50
	RXBH-1724A18J-B	12.8/17.0	1/60	3-5.68	SINGLE	61.6/70.9	5.7	85/96	90/100
		4.3/5.7	1/60	1-5.68	MULTIPLE CKT 1	20.7/23.8	5.7	33/37	35/40
		8.5/11.3	1/60	2-5.68	MULTIPLE CKT 2	40.9/47.1	0	52/59	60/60
	RXBH-24A20J-B	14.4/19.2	1/60	4-4.8	SINGLE	69.3/80	5.7	94/108	100/110
		7.2/9.6	1/60	2-4.8	MULTIPLE CKT 1	34.7/40	5.7	51/58	60/60
		7.2/9.6	1/60	2-4.8	MULTIPLE CKT 2	34.7/40	0	44/50	45/50
	RXBH-24A25J-B	18.0/24.0	1/60	6-4.0	SINGLE	86.6/100	5.7	116/133	125/150
		6.0/8.0	1/60	2-4.0	MULTIPLE CKT 1	28.9/33.4	5.7	44/49	45/50
		6.0/8.0	1/60	2-4.0	MULTIPLE CKT 2	28.9/33.4	0	37/42	40/45
		6.0/8.0	1/60	2-4.0	MULTIPLE CKT 3	28.9/33.4	0	37/42	40/45
	RXBH-24A30J-B	21.6/28.8	1/60	6-4.8	SINGLE	103.9/120	5.7	137/158	150/175
		7.2/9.6	1/60	2-4.8	MULTIPLE CKT 1	34.7/40	5.7	51/58	60/60
		7.2/9.6	1/60	2-4.8	MULTIPLE CKT 2	34.7/40	0	44/50	45/50
		7.2/9.6	1/60	2-4.8	MULTIPLE CKT 3	34.7/40	0	44/50	45/50
	RXBH-17A05C-B	3.6/4.8	3/60	1-4.8	SINGLE	10/11.6	5.7	20/22	20/25
	RXBH-24A05C-B	3.6/4.8	3/60	1-4.8	SINGLE	10/11.6	5.7	20/22	20/25
	RXBH-1724B05C-B	3.6/4.8	3/60	1-4.8	SINGLE	10/11.6	5.7	20/22	20/25
	RXBH-1724A07C-B	5.4/7.2	3/60	2-3.6	SINGLE	15/17.4	5.7	26/29	30/30
	RXBH-1724A10C-B	7.2/9.6	3/60	2-4.8	SINGLE	20/23.1	5.7	33/36	35/40
	RXBH-1724A13C-B	9.4/12.5	3/60	3-4.17	SINGLE	26.1/30.1	5.7	40/45	40/45
	RXBH-1724A15C-B	10.8/14.4	3/60	3-4.8	SINGLE	30/34.7	5.7	45/51	45/60
	RXBH-1724A18C-B	12.8/17.0	3/60	3-5.68	SINGLE	35.6/40.9	5.7	52/59	60/60
	RXBH-24A20C-B	14.4/19.2	3/60	4-4.8	SINGLE	40/46.2	5.7	58/65	60/70
		7.2/9.6	3/60	2-4.8	MULTIPLE CKT 1	20/23.1	5.7	33/36	35/40
		7.2/9.6	3/60	2-4.8	MULTIPLE CKT 2	20/23.1	0	25/29	25/30
	RXBH-24A25C-B	18.0/24.0	3/60	6-4.0	SINGLE	50/57.7	5.7	70/80	70/80
		9.0/12.0	3/60	3-4.0	MULTIPLE CKT 1	25/28.9	5.7	39/44	40/45
		9.0/12.0	3/60	3-4.0	MULTIPLE CKT 2	25/28.9	0	32/37	35/40
	RXBH-24A30C-B	21.6/28.8	3/60	6-4.8	SINGLE	60/69.3	5.7	83/94	90/100
		10.8/14.4	3/60	3-4.8	MULTIPLE CKT 1	30/34.7	5.7	45/51	45/60
10.8/14.4		3/60	3-4.8	MULTIPLE CKT 2	30/34.7	0	38/44	40/45	

? Heater Kit Connection Type A=Breaker B=Terminal Block C=Pullout Disconnect

3.12.5.1 ELECTRICAL DATA - WITH ELECTRIC HEAT: (-)H2VZ - continued

Air Handler Model	Heater Model Number	Heater kW (208/240V)	Ph/Hz	No. Elements - kW per	Circuit Type	Heater Circuit Amps	Tested Blower Motor Amps	Minimum Circuit Ampacity	Maximum Overcurrent Protection
(-)H2VZ6024STANNJ	RXBH-1724?03J-B	2.3/3.0	1/60	1-3.0	SINGLE	11.1/12.5	5.2	21/23	25/25
	RXBH-1724?05J-B	3.6/4.8	1/60	1-4.8	SINGLE	17.4/20	5.2	29/32	30/35
	RXBH-1724?07J-B	5.4/7.2	1/60	2-3.6	SINGLE	26/30	5.2	39/44	40/45
	RXBH-1724?10J-B	7.2/9.6	1/60	2-4.8	SINGLE	34.7/40	5.2	50/57	50/60
	RXBH-1724A13J-B	9.4/12.5	1/60	3-4.17	SINGLE	45.2/52.1	5.2	63/72	70/80
		3.1/4.2	1/60	1-4.17	MULTIPLE CKT 1	15/17.5	5.2	26/29	30/30
		6.3/8.3	1/60	2-4.17	MULTIPLE CKT 2	30.3/34.6	0	38/44	40/45
	RXBH-1724A15J-B	10.8/14.4	1/60	3-4.8	SINGLE	52/60	5.2	72/82	80/90
		3.6/4.8	1/60	1-4.8	MULTIPLE CKT 1	17.4/20	5.2	29/32	30/35
		7.2/9.6	1/60	2-4.8	MULTIPLE CKT 2	34.7/40	0	44/50	45/50
	RXBH-1724A18J-B	12.8/17.0	1/60	3-5.68	SINGLE	61.6/70.9	5.2	84/96	90/100
		4.3/5.7	1/60	1-5.68	MULTIPLE CKT 1	20.7/23.8	5.2	33/37	35/40
		8.5/11.3	1/60	2-5.68	MULTIPLE CKT 2	40.9/47.1	0	52/59	60/60
	RXBH-24A20J-B	14.4/19.2	1/60	4-4.8	SINGLE	69.3/80	5.2	94/107	100/110
		7.2/9.6	1/60	2-4.8	MULTIPLE CKT 1	34.7/40	5.2	50/57	50/60
		7.2/9.6	1/60	2-4.8	MULTIPLE CKT 2	34.7/40	0	44/50	45/50
	RXBH-24A25J-B	18.0/24.0	1/60	6-4.0	SINGLE	86.6/100	5.2	115/132	125/150
		6.0/8.0	1/60	2-4.0	MULTIPLE CKT 1	28.9/33.4	5.2	43/49	45/50
		6.0/8.0	1/60	2-4.0	MULTIPLE CKT 2	28.9/33.4	0	37/42	40/45
		6.0/8.0	1/60	2-4.0	MULTIPLE CKT 3	28.9/33.4	0	37/42	40/45
	RXBH-24A30J-B	21.6/28.8	1/60	6-4.8	SINGLE	103.9/120	5.2	137/157	150/175
		7.2/9.6	1/60	2-4.8	MULTIPLE CKT 1	34.7/40	5.2	50/57	50/60
		7.2/9.6	1/60	2-4.8	MULTIPLE CKT 2	34.7/40	0	44/50	45/50
		7.2/9.6	1/60	2-4.8	MULTIPLE CKT 3	34.7/40	0	44/50	45/50
	RXBH-17A05C-B	3.6/4.8	3/60	1-4.8	SINGLE	10/11.6	5.2	19/21	20/25
	RXBH-24A05C-B	3.6/4.8	3/60	1-4.8	SINGLE	10/11.6	5.2	19/21	20/25
	RXBH-1724B05C-B	3.6/4.8	3/60	1-4.8	SINGLE	10/11.6	5.2	19/21	20/25
	RXBH-1724A07C-B	5.4/7.2	3/60	2-3.6	SINGLE	15/17.4	5.2	26/29	30/30
	RXBH-1724A10C-B	7.2/9.6	3/60	2-4.8	SINGLE	20/23.1	5.2	32/36	35/40
	RXBH-1724A13C-B	9.4/12.5	3/60	3-4.17	SINGLE	26.1/30.1	5.2	40/45	40/45
	RXBH-1724A15C-B	10.8/14.4	3/60	3-4.8	SINGLE	30/34.7	5.2	44/50	45/50
	RXBH-1724A18C-B	12.8/17.0	3/60	3-5.68	SINGLE	35.6/40.9	5.2	51/58	60/60
	RXBH-24A20C-B	14.4/19.2	3/60	4-4.8	SINGLE	40/46.2	5.2	57/65	60/70
		7.2/9.6	3/60	2-4.8	MULTIPLE CKT 1	20/23.1	5.2	32/36	35/40
		7.2/9.6	3/60	2-4.8	MULTIPLE CKT 2	20/23.1	0	25/29	25/30
	RXBH-24A25C-B	18.0/24.0	3/60	6-4.0	SINGLE	50/57.7	5.2	69/79	70/80
		9.0/12.0	3/60	3-4.0	MULTIPLE CKT 1	25/28.9	5.2	38/43	40/45
		9.0/12.0	3/60	3-4.0	MULTIPLE CKT 2	25/28.9	0	32/37	35/40
	RXBH-24A30C-B	21.6/28.8	3/60	6-4.8	SINGLE	60/69.3	5.2	82/94	90/100
		10.8/14.4	3/60	3-4.8	MULTIPLE CKT 1	30/34.7	5.2	44/50	45/50
10.8/14.4		3/60	3-4.8	MULTIPLE CKT 2	30/34.7	0	38/44	40/45	

? Heater Kit Connection Type A=Breaker B=Terminal Block C=Pullout Disconnect

NOTES:

- * Values only. No single point kit available.
- Electric heater BTUH - (heater watts + motor watts) × 3.413 (see airflow table for motor watts.)
- Supply circuit protective devices may be fuses or “HACR” type circuit breakers.
- Motor load is included in single circuit and multiple circuit 1.
- Heater loads are balanced on 3 phase heater kits with 3 or 6 heating elements only.
- J Voltage (230V) single phase air handler is designed to be used with single or three phase 230 volt electric heaters. To connect 3-phase power to the air handler terminal block, bring only two leads to the terminal block, cap, insulate, and fully secure the third lead.
- If the kit is listed under both single and multiple circuits, the heater kit is shipped from factory as multiple circuits. For single phase applications, Jumper bar kit RXBJ-A21 and RXBJ-A31 can be used to convert multiple circuits to a single supply circuit. See Section 6.2 for details.

3.12.5.2 ELECTRICAL DATA - WITH ELECTRIC HEAT: (-)H3VZ

Installation of the UL Listed original equipment manufacturer provided heater kits listed in the following table is recommended for all auxiliary heating requirements.

Air Handler Model	Heater Model Number	Heater kW (208/240V)	Ph/Hz	No. Elements - kW per	Circuit Type	Heater Circuit Amps	Tested Blower Motor Amps	Minimum Circuit Ampacity	Maximum Overcurrent Protection
(-)H3VZ2417STACNJ	RXBH-1724?03J-B	2.3/3.0	1/60	1-3.0	SINGLE	11.1/12.5	2.8	18/20	20/20
	RXBH-1724?05J-B	3.6/4.8	1/60	1-4.8	SINGLE	17.4/20	2.8	26/29	30/30
	RXBH-1724?07J-B	5.4/7.2	1/60	2-3.6	SINGLE	26/30	2.8	36/41	40/45
	RXBH-1724?10J-B	7.2/9.6	1/60	2-4.8	SINGLE	34.7/40	2.8	47/54	50/60
	RXBH-1724A13J-B	9.4/12.5	1/60	3-4.17	SINGLE	45.2/52.1	2.8	60/69	60/70
		3.1/4.2	1/60	1-4.17	MULTIPLE CKT 1	15/17.5	2.8	23/26	25/30
		6.3/8.3	1/60	2-4.17	MULTIPLE CKT 2	30.3/34.6	0	38/44	40/45
	RXBH-17A05C-B	3.6/4.8	3/60	1-4.8	SINGLE	10/11.6	2.8	16/18	20/20
	RXBH-24A05C-B	3.6/4.8	3/60	1-4.8	SINGLE	10/11.6	2.8	16/18	20/20
	RXBH-1724B05C-B	3.6/4.8	3/60	1-4.8	SINGLE	10/11.6	2.8	16/18	20/20
	RXBH-1724A07C-B	5.4/7.2	3/60	2-3.6	SINGLE	15/17.4	2.8	23/26	25/30
	RXBH-1724A10C-B	7.2/9.6	3/60	2-4.8	SINGLE	20/23.1	2.8	29/33	30/35
RXBH-1724A13C-B	9.4/12.5	3/60	3-4.17	SINGLE	26.1/30.1	2.8	37/42	40/45	
(-)H3VZ2417MTACNJ (-)H3VZ3617STACNJ	RXBH-1724?03J-B	2.3/3.0	1/60	1-3.0	SINGLE	11.1/12.5	4.6	20/22	20/25
	RXBH-1724?05J-B	3.6/4.8	1/60	1-4.8	SINGLE	17.4/20	4.6	28/31	30/35
	RXBH-1724?07J-B	5.4/7.2	1/60	2-3.6	SINGLE	26/30	4.6	39/44	40/45
	RXBH-1724?10J-B	7.2/9.6	1/60	2-4.8	SINGLE	34.7/40	4.6	50/56	50/60
	RXBH-1724A13J-B	9.4/12.5	1/60	3-4.17	SINGLE	45.2/52.1	4.6	63/71	70/80
		3.1/4.2	1/60	1-4.17	MULTIPLE CKT 1	15/17.5	4.6	25/28	25/30
		6.3/8.3	1/60	2-4.17	MULTIPLE CKT 2	30.3/34.6	0	38/44	40/45
	RXBH-1724A15J-B	10.8/14.4	1/60	3-4.8	SINGLE	52/60	4.6	71/81	80/90
		3.6/4.8	1/60	1-4.8	MULTIPLE CKT 1	17.4/20	4.6	28/31	30/35
		7.2/9.6	1/60	2-4.8	MULTIPLE CKT 2	34.7/40	0	44/50	45/50
	RXBH-1724A18J-B	12.8/17.0	1/60	3-5.68	SINGLE	61.6/70.9	4.6	83/95	90/100
		4.3/5.7	1/60	1-5.68	MULTIPLE CKT 1	20.7/23.8	4.6	32/36	35/40
		8.5/11.3	1/60	2-5.68	MULTIPLE CKT 2	40.9/47.1	0	52/59	60/60
	RXBH-17A05C-B	3.6/4.8	3/60	1-4.8	SINGLE	10/11.6	4.6	19/21	20/25
	RXBH-24A05C-B	3.6/4.8	3/60	1-4.8	SINGLE	10/11.6	4.6	19/21	20/25
	RXBH-1724B05C-B	3.6/4.8	3/60	1-4.8	SINGLE	10/11.6	4.6	19/21	20/25
	RXBH-1724A07C-B	5.4/7.2	3/60	2-3.6	SINGLE	15/17.4	4.6	25/28	25/30
	RXBH-1724A10C-B	7.2/9.6	3/60	2-4.8	SINGLE	20/23.1	4.6	31/35	35/35
	RXBH-1724A13C-B	9.4/12.5	3/60	3-4.17	SINGLE	26.1/30.1	4.6	39/44	40/45
	RXBH-1724A15C-B	10.8/14.4	3/60	3-4.8	SINGLE	30/34.7	4.6	44/50	45/50
RXBH-1724A18C-B	12.8/17.0	3/60	3-5.68	SINGLE	35.6/40.9	4.6	51/57	60/60	

? Heater Kit Connection Type A = Breaker B = Terminal Block C = Pullout Disconnect

3.12.5.2 ELECTRICAL DATA - WITH ELECTRIC HEAT: (-)H3VZ - continued

Air Handler Model	Heater Model Number	Heater kW (208/240V)	Ph/Hz	No. Elements - kW per	Circuit Type	Heater Circuit Amps	Tested Blower Motor Amps	Minimum Circuit Ampacity	Maximum Overcurrent Protection
(-)H3VZ3621MTACNJ (-)H3VZ4821STACNJ	RXBH-1724?03J-B	2.3/3.0	1/60	1-3.0	SINGLE	11.1/12.5	5.4	21/23	25/25
	RXBH-1724?05J-B	3.6/4.8	1/60	1-4.8	SINGLE	17.4/20	5.4	29/32	30/35
	RXBH-1724?07J-B	5.4/7.2	1/60	2-3.6	SINGLE	26/30	5.4	40/45	40/45
	RXBH-1724?10J-B	7.2/9.6	1/60	2-4.8	SINGLE	34.7/40	5.4	51/57	60/60
	RXBH-1724A13J-B	9.4/12.5	1/60	3-4.17	SINGLE	45.2/52.1	5.4	64/72	70/80
		3.1/4.2	1/60	1-4.17	MULTIPLE CKT 1	15/17.5	5.4	26/29	30/30
		6.3/8.3	1/60	2-4.17	MULTIPLE CKT 2	30.3/34.6	0	38/44	40/45
	RXBH-1724A15J-B	10.8/14.4	1/60	3-4.8	SINGLE	52/60	5.4	72/82	80/90
		3.6/4.8	1/60	1-4.8	MULTIPLE CKT 1	17.4/20	5.4	29/32	30/35
		7.2/9.6	1/60	2-4.8	MULTIPLE CKT 2	34.7/40	0	44/50	45/50
	RXBH-1724A18J-B	12.8/17.0	1/60	3-5.68	SINGLE	61.6/70.9	5.4	84/96	90/100
		4.3/5.7	1/60	1-5.68	MULTIPLE CKT 1	20.7/23.8	5.4	33/37	35/40
		8.5/11.3	1/60	2-5.68	MULTIPLE CKT 2	40.9/47.1	0	52/59	60/60
	RXBH-24A20J-B	14.4/19.2	1/60	4-4.8	SINGLE	69.3/80	5.4	94/107	100/110
		7.2/9.6	1/60	2-4.8	MULTIPLE CKT 1	34.7/40	5.4	51/57	60/60
		7.2/9.6	1/60	2-4.8	MULTIPLE CKT 2	34.7/40	0	44/50	45/50
	RXBH-24A25J-B	18.0/24.0	1/60	6-4.0	SINGLE	86.6/100	5.4	115/132	125/150
		6.0/8.0	1/60	2-4.0	MULTIPLE CKT 1	28.9/33.4	5.4	43/49	45/50
		6.0/8.0	1/60	2-4.0	MULTIPLE CKT 2	28.9/33.4	0	37/42	40/45
		6.0/8.0	1/60	2-4.0	MULTIPLE CKT 3	28.9/33.4	0	37/42	40/45
	RXBH-24A30J-B	21.6/28.8	1/60	6-4.8	SINGLE	103.9/120	5.4	137/157	150/175
		7.2/9.6	1/60	2-4.8	MULTIPLE CKT 1	34.7/40	5.4	51/57	60/60
		7.2/9.6	1/60	2-4.8	MULTIPLE CKT 2	34.7/40	0	44/50	45/50
		7.2/9.6	1/60	2-4.8	MULTIPLE CKT 3	34.7/40	0	44/50	45/50
	RXBH-17A05C-B	3.6/4.8	3/60	1-4.8	SINGLE	10/11.6	5.4	20/22	20/25
	RXBH-24A05C-B	3.6/4.8	3/60	1-4.8	SINGLE	10/11.6	5.4	20/22	20/25
	RXBH-1724B05C-B	3.6/4.8	3/60	1-4.8	SINGLE	10/11.6	5.4	20/22	20/25
	RXBH-1724A07C-B	5.4/7.2	3/60	2-3.6	SINGLE	15/17.4	5.4	26/29	30/30
	RXBH-1724A10C-B	7.2/9.6	3/60	2-4.8	SINGLE	20/23.1	5.4	32/36	35/40
	RXBH-1724A13C-B	9.4/12.5	3/60	3-4.17	SINGLE	26.1/30.1	5.4	40/45	40/45
	RXBH-1724A15C-B	10.8/14.4	3/60	3-4.8	SINGLE	30/34.7	5.4	45/51	45/60
	RXBH-1724A18C-B	12.8/17.0	3/60	3-5.68	SINGLE	35.6/40.9	5.4	52/58	60/60
	RXBH-24A20C-B	14.4/19.2	3/60	4-4.8	SINGLE	40/46.2	5.4	57/65	60/70
		7.2/9.6	3/60	2-4.8	MULTIPLE CKT 1	20/23.1	5.4	32/36	35/40
		7.2/9.6	3/60	2-4.8	MULTIPLE CKT 2	20/23.1	0	25/29	25/30
	RXBH-24A25C-B	18.0/24.0	3/60	6-4.0	SINGLE	50/57.7	5.4	70/79	70/80
		9.0/12.0	3/60	3-4.0	MULTIPLE CKT 1	25/28.9	5.4	38/43	40/45
		9.0/12.0	3/60	3-4.0	MULTIPLE CKT 2	25/28.9	0	32/37	35/40
	RXBH-24A30C-B	21.6/28.8	3/60	6-4.8	SINGLE	60/69.3	5.4	82/94	90/100
		10.8/14.4	3/60	3-4.8	MULTIPLE CKT 1	30/34.7	5.4	45/51	45/60
		10.8/14.4	3/60	3-4.8	MULTIPLE CKT 2	30/34.7	0	38/44	40/45

? Heater Kit Connection Type A = Breaker B = Terminal Block C = Pullout Disconnect

3.12.5.2 ELECTRICAL DATA - WITH ELECTRIC HEAT: (-)H3VZ - continued

Air Handler Model	Heater Model Number	Heater kW (208/240V)	Ph/Hz	No. Elements - kW per	Circuit Type	Heater Circuit Amps	Tested Blower Motor Amps	Minimum Circuit Ampacity	Maximum Overcurrent Protection
(-)H3VZ4824STACNJ (-)H3VZ6024STACNJ	RXBH-1724?03J-B	2.3/3.0	1/60	1-3.0	SINGLE	11.1/12.5	5.2	21/23	25/25
	RXBH-1724?05J-B	3.6/4.8	1/60	1-4.8	SINGLE	17.4/20	5.2	29/32	30/35
	RXBH-1724?07J-B	5.4/7.2	1/60	2-3.6	SINGLE	26/30	5.2	39/44	40/45
	RXBH-1724?10J-B	7.2/9.6	1/60	2-4.8	SINGLE	34.7/40	5.2	50/57	50/60
	RXBH-1724A13J-B	9.4/12.5	1/60	3-4.17	SINGLE	45.2/52.1	5.2	63/72	70/80
		3.1/4.2	1/60	1-4.17	MULTIPLE CKT 1	15/17.5	5.2	26/29	30/30
	RXBH-1724A15J-B	6.3/8.3	1/60	2-4.17	MULTIPLE CKT 2	30.3/34.6	0	38/44	40/45
		10.8/14.4	1/60	3-4.8	SINGLE	52/60	5.2	72/82	80/90
	RXBH-1724A18J-B	3.6/4.8	1/60	1-4.8	MULTIPLE CKT 1	17.4/20	5.2	29/32	30/35
		7.2/9.6	1/60	2-4.8	MULTIPLE CKT 2	34.7/40	0	44/50	45/50
	RXBH-24A20J-B	12.8/17.0	1/60	3-5.68	SINGLE	61.6/70.9	5.2	84/96	90/100
		4.3/5.7	1/60	1-5.68	MULTIPLE CKT 1	20.7/23.8	5.2	33/37	35/40
		8.5/11.3	1/60	2-5.68	MULTIPLE CKT 2	40.9/47.1	0	52/59	60/60
	RXBH-24A25J-B	14.4/19.2	1/60	4-4.8	SINGLE	69.3/80	5.2	94/107	100/110
		7.2/9.6	1/60	2-4.8	MULTIPLE CKT 1	34.7/40	5.2	50/57	50/60
	RXBH-24A30J-B	7.2/9.6	1/60	2-4.8	MULTIPLE CKT 2	34.7/40	0	44/50	45/50
		18.0/24.0	1/60	6-4.0	SINGLE	86.6/100	5.2	115/132	125/150
		6.0/8.0	1/60	2-4.0	MULTIPLE CKT 1	28.9/33.4	5.2	43/49	45/50
	RXBH-17A05C-B	6.0/8.0	1/60	2-4.0	MULTIPLE CKT 2	28.9/33.4	0	37/42	40/45
		6.0/8.0	1/60	2-4.0	MULTIPLE CKT 3	28.9/33.4	0	37/42	40/45
		21.6/28.8	1/60	6-4.8	SINGLE	103.9/120	5.2	137/157	150/175
		7.2/9.6	1/60	2-4.8	MULTIPLE CKT 1	34.7/40	5.2	50/57	50/60
	RXBH-24A05C-B	7.2/9.6	1/60	2-4.8	MULTIPLE CKT 2	34.7/40	0	44/50	45/50
		7.2/9.6	1/60	2-4.8	MULTIPLE CKT 3	34.7/40	0	44/50	45/50
	RXBH-1724B05C-B	3.6/4.8	3/60	1-4.8	SINGLE	10/11.6	5.2	19/21	20/25
	RXBH-1724A07C-B	3.6/4.8	3/60	1-4.8	SINGLE	10/11.6	5.2	19/21	20/25
	RXBH-1724A10C-B	3.6/4.8	3/60	1-4.8	SINGLE	10/11.6	5.2	19/21	20/25
	RXBH-1724A13C-B	5.4/7.2	3/60	2-3.6	SINGLE	15/17.4	5.2	26/29	30/30
	RXBH-1724A15C-B	7.2/9.6	3/60	2-4.8	SINGLE	20/23.1	5.2	32/36	35/40
	RXBH-1724A18C-B	9.4/12.5	3/60	3-4.17	SINGLE	26.1/30.1	5.2	40/45	40/45
	RXBH-24A20C-B	10.8/14.4	3/60	3-4.8	SINGLE	30/34.7	5.2	44/50	45/50
		12.8/17.0	3/60	3-5.68	SINGLE	35.6/40.9	5.2	51/58	60/60
		14.4/19.2	3/60	4-4.8	SINGLE	40/46.2	5.2	57/65	60/70
	RXBH-24A25C-B	7.2/9.6	3/60	2-4.8	MULTIPLE CKT 1	20/23.1	5.2	32/36	35/40
		7.2/9.6	3/60	2-4.8	MULTIPLE CKT 2	20/23.1	0	25/29	25/30
		18.0/24.0	3/60	6-4.0	SINGLE	50/57.7	5.2	69/79	70/80
	RXBH-24A30C-B	9.0/12.0	3/60	3-4.0	MULTIPLE CKT 1	25/28.9	5.2	38/43	40/45
		9.0/12.0	3/60	3-4.0	MULTIPLE CKT 2	25/28.9	0	32/37	35/40
	RXBH-24A30C-B	21.6/28.8	3/60	6-4.8	SINGLE	60/69.3	5.2	82/94	90/100
		10.8/14.4	3/60	3-4.8	MULTIPLE CKT 1	30/34.7	5.2	44/50	45/50
	10.8/14.4	3/60	3-4.8	MULTIPLE CKT 2	30/34.7	0	38/44	40/45	

? Heater Kit Connection Type A = Breaker B = Terminal Block C = Pullout Disconnect

NOTES:

- * Values only. No single point kit available.
- Electric heater BTUH - (heater watts + motor watts) × 3.413 (see airflow table for motor watts.)
- Supply circuit protective devices may be fuses or “HACR” type circuit breakers.
- Motor load is included in single circuit and multiple circuit 1.
- Heater loads are balanced on 3 phase heater kits with 3 or 6 heating elements only.
- J Voltage (230V) single phase air handler is designed to be used with single or three phase 230 volt electric heaters. To connect 3-phase power to the air handler terminal block, bring only two leads to the terminal block, cap, insulate, and fully secure the third lead.
- If the kit is listed under both single and multiple circuits, the heater kit is shipped from factory as multiple circuits. For single phase applications, Jumper bar kit RXBJ-A21 and RXBJ-A31 can be used to convert multiple circuits to a single supply circuit. See Section 6.2 for details.

3.12.5.3 ELECTRICAL DATA - WITH ELECTRIC HEAT: (-)HMVZ

Installation of the UL Listed original equipment manufacturer provided heater kits listed in the following table is recommended for all auxiliary heating requirements.

Air Handler Model	Heater Model Number	Heater kW (208/240V)	Ph/Hz	No. Elements - kW per	Circuit Type	Heater Circuit Amps	Tested Blower Motor Amps	Minimum Circuit Ampacity	Maximum Overcurrent Protection
(-)HMVZ2417SEACNJ	RXBH-1724?03J-B	2.3/3.0	1/60	1-3.0	SINGLE	11.1/12.5	2.8	18/20	20/20
	RXBH-1724?05J-B	3.6/4.8	1/60	1-4.8	SINGLE	17.4/20	2.8	26/29	30/30
	RXBH-1724?07J-B	5.4/7.2	1/60	2-3.6	SINGLE	26/30	2.8	36/41	40/45
	RXBH-1724?10J-B	7.2/9.6	1/60	2-4.8	SINGLE	34.7/40	2.8	47/54	50/60
	RXBH-1724A13J-B	9.4/12.5	1/60	3-4.17	SINGLE	45.2/52.1	2.8	60/69	60/70
		3.1/4.2	1/60	1-4.17	MULTIPLE CKT 1	15/17.5	2.8	23/26	25/30
		6.3/8.3	1/60	2-4.17	MULTIPLE CKT 2	30.3/34.6	0	38/44	40/45
	RXBH-17A05C-B	3.6/4.8	3/60	1-4.8	SINGLE	10/11.6	2.8	16/18	20/20
	RXBH-24A05C-B	3.6/4.8	3/60	1-4.8	SINGLE	10/11.6	2.8	16/18	20/20
	RXBH-1724B05C-B	3.6/4.8	3/60	1-4.8	SINGLE	10/11.6	2.8	16/18	20/20
	RXBH-1724A07C-B	5.4/7.2	3/60	2-3.6	SINGLE	15/17.4	2.8	23/26	25/30
RXBH-1724A10C-B	7.2/9.6	3/60	2-4.8	SINGLE	20/23.1	2.8	29/33	30/35	
RXBH-1724A13C-B	9.4/12.5	3/60	3-4.17	SINGLE	26.1/30.1	2.8	37/42	40/45	
(-)HMVZ2421MEACNJ	RXBH-1724?03J-B	2.3/3.0	1/60	1-3.0	SINGLE	11.1/12.5	2.7	18/19	20/20
	RXBH-1724?05J-B	3.6/4.8	1/60	1-4.8	SINGLE	17.4/20	2.7	26/29	30/30
	RXBH-1724?07J-B	5.4/7.2	1/60	2-3.6	SINGLE	26/30	2.7	36/41	40/45
	RXBH-1724?10J-B	7.2/9.6	1/60	2-4.8	SINGLE	34.7/40	2.7	47/54	50/60
	RXBH-1724A13J-B	9.4/12.5	1/60	3-4.17	SINGLE	45.2/52.1	2.7	60/69	60/70
		3.1/4.2	1/60	1-4.17	MULTIPLE CKT 1	15/17.5	2.7	23/26	25/30
		6.3/8.3	1/60	2-4.17	MULTIPLE CKT 2	30.3/34.6	0	38/44	40/45
	RXBH-17A05C-B	3.6/4.8	3/60	1-4.8	SINGLE	10/11.6	2.7	16/18	20/20
	RXBH-24A05C-B	3.6/4.8	3/60	1-4.8	SINGLE	10/11.6	2.7	16/18	20/20
	RXBH-1724B05C-B	3.6/4.8	3/60	1-4.8	SINGLE	10/11.6	2.7	16/18	20/20
	RXBH-1724A07C-B	5.4/7.2	3/60	2-3.6	SINGLE	15/17.4	2.7	23/26	25/30
RXBH-1724A10C-B	7.2/9.6	3/60	2-4.8	SINGLE	20/23.1	2.7	29/33	30/35	
RXBH-1724A13C-B	9.4/12.5	3/60	3-4.17	SINGLE	26.1/30.1	2.7	36/41	40/45	
(-)HMVZ2421HEACNJ	RXBH-1724?03J-B	2.3/3.0	1/60	1-3.0	SINGLE	11.1/12.5	3.5	19/20	20/20
	RXBH-1724?05J-B	3.6/4.8	1/60	1-4.8	SINGLE	17.4/20	3.5	27/30	30/30
	RXBH-1724?07J-B	5.4/7.2	1/60	2-3.6	SINGLE	26/30	3.5	37/42	40/45
	RXBH-1724?10J-B	7.2/9.6	1/60	2-4.8	SINGLE	34.7/40	3.5	48/55	50/60
	RXBH-1724A13J-B	9.4/12.5	1/60	3-4.17	SINGLE	45.2/52.1	3.5	61/70	70/70
		3.1/4.2	1/60	1-4.17	MULTIPLE CKT 1	15/17.5	3.5	24/27	25/30
		6.3/8.3	1/60	2-4.17	MULTIPLE CKT 2	30.3/34.6	0	38/44	40/45
	RXBH-17A05C-B	3.6/4.8	3/60	1-4.8	SINGLE	10/11.6	3.5	17/19	20/20
	RXBH-24A05C-B	3.6/4.8	3/60	1-4.8	SINGLE	10/11.6	3.5	17/19	20/20
	RXBH-1724B05C-B	3.6/4.8	3/60	1-4.8	SINGLE	10/11.6	3.5	17/19	20/20
	RXBH-1724A07C-B	5.4/7.2	3/60	2-3.6	SINGLE	15/17.4	3.5	24/27	25/30
RXBH-1724A10C-B	7.2/9.6	3/60	2-4.8	SINGLE	20/23.1	3.5	30/34	30/35	
RXBH-1724A13C-B	9.4/12.5	3/60	3-4.17	SINGLE	26.1/30.1	3.5	37/42	40/45	
(-)HMVZ2421HEACAJ	RXBH-1724?03J-B	2.3/3.0	1/60	1-3.0	SINGLE	11.1/12.5	5.7	21/23	25/25
	RXBH-1724?05J-B	3.6/4.8	1/60	1-4.8	SINGLE	17.4/20	5.7	29/33	30/35
	RXBH-1724?07J-B	5.4/7.2	1/60	2-3.6	SINGLE	26/30	5.7	40/45	40/45
	RXBH-1724?10J-B	7.2/9.6	1/60	2-4.8	SINGLE	34.7/40	5.7	51/58	60/60
	RXBH-1724A13J-B	9.4/12.5	1/60	3-4.17	SINGLE	45.2/52.1	5.7	64/73	70/80
		3.1/4.2	1/60	1-4.17	MULTIPLE CKT 1	15/17.5	5.7	26/29	30/30
		6.3/8.3	1/60	2-4.17	MULTIPLE CKT 2	30.3/34.6	0	38/44	40/45
	RXBH-17A05C-B	3.6/4.8	3/60	1-4.8	SINGLE	10/11.6	5.7	20/22	20/25
	RXBH-24A05C-B	3.6/4.8	3/60	1-4.8	SINGLE	10/11.6	5.7	20/22	20/25
	RXBH-1724B05C-B	3.6/4.8	3/60	1-4.8	SINGLE	10/11.6	5.7	20/22	20/25
	RXBH-1724A07C-B	5.4/7.2	3/60	2-3.6	SINGLE	15/17.4	5.7	26/29	30/30
RXBH-1724A10C-B	7.2/9.6	3/60	2-4.8	SINGLE	20/23.1	5.7	33/36	35/40	
RXBH-1724A13C-B	9.4/12.5	3/60	3-4.17	SINGLE	26.1/30.1	5.7	40/45	40/45	

? Heater Kit Connection Type A = Breaker B = Terminal Block C = Pullout Disconnect

3.12.5.3 Electrical Data - With Electric Heat: (-)HVMZ - continued

Air Handler Model	Heater Model Number	Heater kW (208/240V)	Ph/Hz	No. Elements - kW per	Circuit Type	Heater Circuit Amps	Tested Blower Motor Amps	Minimum Circuit Ampacity	Maximum Overcurrent Protection
(-)HVMZ6021SEACAJ	RXBH-1724?03J-B	2.3/3.0	1/60	1-3.0	SINGLE	11.1/12.5	5.7	21/23	25/25
	RXBH-1724?05J-B	3.6/4.8	1/60	1-4.8	SINGLE	17.4/20	5.7	29/33	30/35
	RXBH-1724?07J-B	5.4/7.2	1/60	2-3.6	SINGLE	26/30	5.7	40/45	40/45
	RXBH-1724?10J-B	7.2/9.6	1/60	2-4.8	SINGLE	34.7/40	5.7	51/58	60/60
	RXBH-1724A13J-B	9.4/12.5	1/60	3-4.17	SINGLE	45.2/52.1	5.7	64/73	70/80
		3.1/4.2	1/60	1-4.17	MULTIPLE CKT 1	15/17.5	5.7	26/29	30/30
		6.3/8.3	1/60	2-4.17	MULTIPLE CKT 2	30.3/34.6	0	38/44	40/45
	RXBH-1724A15J-B	10.8/14.4	1/60	3-4.8	SINGLE	52/60	5.7	73/83	80/90
		3.6/4.8	1/60	1-4.8	MULTIPLE CKT 1	17.4/20	5.7	29/33	30/35
		7.2/9.6	1/60	2-4.8	MULTIPLE CKT 2	34.7/40	0	44/50	45/50
	RXBH-1724A18J-B	12.8/17.0	1/60	3-5.68	SINGLE	61.6/70.9	5.7	85/96	90/100
		4.3/5.7	1/60	1-5.68	MULTIPLE CKT 1	20.7/23.8	5.7	33/37	35/40
		8.5/11.3	1/60	2-5.68	MULTIPLE CKT 2	40.9/47.1	0	52/59	60/60
	RXBH-24A20J-B	14.4/19.2	1/60	4-4.8	SINGLE	69.3/80	5.7	94/108	100/110
		7.2/9.6	1/60	2-4.8	MULTIPLE CKT 1	34.7/40	5.7	51/58	60/60
		7.2/9.6	1/60	2-4.8	MULTIPLE CKT 2	34.7/40	0	44/50	45/50
	RXBH-24A25J-B	18.0/24.0	1/60	6-4.0	SINGLE	86.6/100	5.7	116/133	125/150
		6.0/8.0	1/60	2-4.0	MULTIPLE CKT 1	28.9/33.4	5.7	44/49	45/50
		6.0/8.0	1/60	2-4.0	MULTIPLE CKT 2	28.9/33.4	0	37/42	40/45
		6.0/8.0	1/60	2-4.0	MULTIPLE CKT 3	28.9/33.4	0	37/42	40/45
	RXBH-24A30J-B	21.6/28.8	1/60	6-4.8	SINGLE	103.9/120	5.7	137/158	150/175
		7.2/9.6	1/60	2-4.8	MULTIPLE CKT 1	34.7/40	5.7	51/58	60/60
		7.2/9.6	1/60	2-4.8	MULTIPLE CKT 2	34.7/40	0	44/50	45/50
		7.2/9.6	1/60	2-4.8	MULTIPLE CKT 3	34.7/40	0	44/50	45/50
	RXBH-17A05C-B	3.6/4.8	3/60	1-4.8	SINGLE	10/11.6	5.7	20/22	20/25
	RXBH-24A05C-B	3.6/4.8	3/60	1-4.8	SINGLE	10/11.6	5.7	20/22	20/25
	RXBH-1724B05C-B	3.6/4.8	3/60	1-4.8	SINGLE	10/11.6	5.7	20/22	20/25
	RXBH-1724A07C-B	5.4/7.2	3/60	2-3.6	SINGLE	15/17.4	5.7	26/29	30/30
	RXBH-1724A10C-B	7.2/9.6	3/60	2-4.8	SINGLE	20/23.1	5.7	33/36	35/40
	RXBH-1724A13C-B	9.4/12.5	3/60	3-4.17	SINGLE	26.1/30.1	5.7	40/45	40/45
	RXBH-1724A15C-B	10.8/14.4	3/60	3-4.8	SINGLE	30/34.7	5.7	45/51	45/60
	RXBH-1724A18C-B	12.8/17.0	3/60	3-5.68	SINGLE	35.6/40.9	5.7	52/59	60/60
	RXBH-24A20C-B	14.4/19.2	3/60	4-4.8	SINGLE	40/46.2	5.7	58/65	60/70
		7.2/9.6	3/60	2-4.8	MULTIPLE CKT 1	20/23.1	5.7	33/36	35/40
		7.2/9.6	3/60	2-4.8	MULTIPLE CKT 2	20/23.1	0	25/29	25/30
	RXBH-24A25C-B	18.0/24.0	3/60	6-4.0	SINGLE	50/57.7	5.7	70/80	70/80
		9.0/12.0	3/60	3-4.0	MULTIPLE CKT 1	25/28.9	5.7	39/44	40/45
		9.0/12.0	3/60	3-4.0	MULTIPLE CKT 2	25/28.9	0	32/37	35/40
	RXBH-24A30C-B	21.6/28.8	3/60	6-4.8	SINGLE	60/69.3	5.7	83/94	90/100
		10.8/14.4	3/60	3-4.8	MULTIPLE CKT 1	30/34.7	5.7	45/51	45/60
10.8/14.4		3/60	3-4.8	MULTIPLE CKT 2	30/34.7	0	38/44	40/45	

? Heater Kit Connection Type A = Breaker B = Terminal Block C = Pullout Disconnect

3.12.5.3 Electrical Data - With Electric Heat: (-)HVMZ - continued

Air Handler Model	Heater Model Number	Heater kW (208/240V)	Ph/Hz	No. Elements - kW per	Circuit Type	Heater Circuit Amps	Tested Blower Motor Amps	Minimum Circuit Ampacity	Maximum Overcurrent Protection
(-)HVMZ6024SEACNJ	RXBH-1724?03J-B	2.3/3.0	1/60	1-3.0	SINGLE	11.1/12.5	5.2	21/23	25/25
	RXBH-1724?05J-B	3.6/4.8	1/60	1-4.8	SINGLE	17.4/20	5.2	29/32	30/35
	RXBH-1724?07J-B	5.4/7.2	1/60	2-3.6	SINGLE	26/30	5.2	39/44	40/45
	RXBH-1724?10J-B	7.2/9.6	1/60	2-4.8	SINGLE	34.7/40	5.2	50/57	50/60
	RXBH-1724A13J-B	9.4/12.5	1/60	3-4.17	SINGLE	45.2/52.1	5.2	63/72	70/80
		3.1/4.2	1/60	1-4.17	MULTIPLE CKT 1	15/17.5	5.2	26/29	30/30
		6.3/8.3	1/60	2-4.17	MULTIPLE CKT 2	30.3/34.6	0	38/44	40/45
	RXBH-1724A15J-B	10.8/14.4	1/60	3-4.8	SINGLE	52/60	5.2	72/82	80/90
		3.6/4.8	1/60	1-4.8	MULTIPLE CKT 1	17.4/20	5.2	29/32	30/35
		7.2/9.6	1/60	2-4.8	MULTIPLE CKT 2	34.7/40	0	44/50	45/50
	RXBH-1724A18J-B	12.8/17.0	1/60	3-5.68	SINGLE	61.6/70.9	5.2	84/96	90/100
		4.3/5.7	1/60	1-5.68	MULTIPLE CKT 1	20.7/23.8	5.2	33/37	35/40
		8.5/11.3	1/60	2-5.68	MULTIPLE CKT 2	40.9/47.1	0	52/59	60/60
	RXBH-24A20J-B	14.4/19.2	1/60	4-4.8	SINGLE	69.3/80	5.2	94/107	100/110
		7.2/9.6	1/60	2-4.8	MULTIPLE CKT 1	34.7/40	5.2	50/57	50/60
		7.2/9.6	1/60	2-4.8	MULTIPLE CKT 2	34.7/40	0	44/50	45/50
	RXBH-24A25J-B	18.0/24.0	1/60	6-4.0	SINGLE	86.6/100	5.2	115/132	125/150
		6.0/8.0	1/60	2-4.0	MULTIPLE CKT 1	28.9/33.4	5.2	43/49	45/50
		6.0/8.0	1/60	2-4.0	MULTIPLE CKT 2	28.9/33.4	0	37/42	40/45
		6.0/8.0	1/60	2-4.0	MULTIPLE CKT 3	28.9/33.4	0	37/42	40/45
	RXBH-24A30J-B	21.6/28.8	1/60	6-4.8	SINGLE	103.9/120	5.2	137/157	150/175
		7.2/9.6	1/60	2-4.8	MULTIPLE CKT 1	34.7/40	5.2	50/57	50/60
		7.2/9.6	1/60	2-4.8	MULTIPLE CKT 2	34.7/40	0	44/50	45/50
		7.2/9.6	1/60	2-4.8	MULTIPLE CKT 3	34.7/40	0	44/50	45/50
	RXBH-17A05C-B	3.6/4.8	3/60	1-4.8	SINGLE	10/11.6	5.2	19/21	20/25
	RXBH-24A05C-B	3.6/4.8	3/60	1-4.8	SINGLE	10/11.6	5.2	19/21	20/25
	RXBH-1724B05C-B	3.6/4.8	3/60	1-4.8	SINGLE	10/11.6	5.2	19/21	20/25
	RXBH-1724A07C-B	5.4/7.2	3/60	2-3.6	SINGLE	15/17.4	5.2	26/29	30/30
	RXBH-1724A10C-B	7.2/9.6	3/60	2-4.8	SINGLE	20/23.1	5.2	32/36	35/40
	RXBH-1724A13C-B	9.4/12.5	3/60	3-4.17	SINGLE	26.1/30.1	5.2	40/45	40/45
	RXBH-1724A15C-B	10.8/14.4	3/60	3-4.8	SINGLE	30/34.7	5.2	44/50	45/50
	RXBH-1724A18C-B	12.8/17.0	3/60	3-5.68	SINGLE	35.6/40.9	5.2	51/58	60/60
	RXBH-24A20C-B	14.4/19.2	3/60	4-4.8	SINGLE	40/46.2	5.2	57/65	60/70
		7.2/9.6	3/60	2-4.8	MULTIPLE CKT 1	20/23.1	5.2	32/36	35/40
		7.2/9.6	3/60	2-4.8	MULTIPLE CKT 2	20/23.1	0	25/29	25/30
	RXBH-24A25C-B	18.0/24.0	3/60	6-4.0	SINGLE	50/57.7	5.2	69/79	70/80
		9.0/12.0	3/60	3-4.0	MULTIPLE CKT 1	25/28.9	5.2	38/43	40/45
		9.0/12.0	3/60	3-4.0	MULTIPLE CKT 2	25/28.9	0	32/37	35/40
	RXBH-24A30C-B	21.6/28.8	3/60	6-4.8	SINGLE	60/69.3	5.2	82/94	90/100
		10.8/14.4	3/60	3-4.8	MULTIPLE CKT 1	30/34.7	5.2	44/50	45/50
10.8/14.4		3/60	3-4.8	MULTIPLE CKT 2	30/34.7	0	38/44	40/45	

? Heater Kit Connection Type A = Breaker B = Terminal Block C = Pullout Disconnect

NOTES:

- * Values only. No single point kit available.
- Electric heater BTUH - (heater watts + motor watts) × 3.413 (see airflow table for motor watts.)
- Supply circuit protective devices may be fuses or “HACR” type circuit breakers.
- Motor load is included in single circuit and multiple circuit 1.
- Heater loads are balanced on 3 phase heater kits with 3 or 6 heating elements only.
- J Voltage (230V) single phase air handler is designed to be used with single or three phase 230 volt electric heaters. To connect 3-phase power to the air handler terminal block, bring only two leads to the terminal block, cap, insulate, and fully secure the third lead.
- If the kit is listed under both single and multiple circuits, the heater kit is shipped from factory as multiple circuits. For single phase applications, Jumper bar kit RXBJ-A21 and RXBJ-A31 can be used to convert multiple circuits to a single supply circuit. See Section 6.2 for details.

3.12.6 ELECTRIC HEATER KIT SUPPLEMENTAL INFORMATION

MFD: MO./YEAR 01/2006
FRQ: MO./JANNE

AIR CONDITIONING DIVISION

MADE IN THE U.S.A. FAIT DANS L'USA

MODEL/MODELE # 208/240 PH/HZ 1/60 SERIAL/EN SERIE # W0118 38751
VOLTS 208/240 MOTOR HP./F.L.A. 1/2 4.1
MOTEUR PSC/F.L.A.

ATTENTION: MARK HEATER INSTALLED! L'APPAREIL DE CHAUFFAGE DE MARQUE A INSTALLER

HEATER MODEL/MODELE D'APPAREIL DE CHAUFFAGE	TYPE SUPPLY CIRCUIT/TYPES LE CIRCUIT DE PROVISION	VOLTAGE/TENSION	PHASE	KW	HEATER AMPS/AMPLIS D'APPAREIL DE CHAUFFAGE	MOTOR AMPS/LES AMPLIS MOTEURS	MAXIMUM OVERCURRENT PROTECTION LA PROTECTION MAXIMUM DE L'OVERCURRENT	MINIMUM BRANCH CIRCUIT AMPACITY/AMPCAPTE MINIMUM DE CIRCUIT DE BRANCHE
NO HEAT				0.0		4.1	15	5.2
RXBH-24A05J	SINGLE	208/240	1/60	3.6/4.8	17.3/20.0	6.0	30/35	30/33
RXBH-24A07J	SINGLE	208/240	1/60	5.4/7.2	26.0/30.0	6.0	40/45	40/45
RXBH-24A10J	SINGLE	208/240	1/60	7.2/9.6	34.6/40.0	6.0	60/60	51/58
RXBH-24A15J	SINGLE	208/240	1/60	10.8/14.4	51.9/60.0	6.0	80/90	73/83
RXBH-24A15J	MULTI CKT 1	208/240	1/60	3.6/4.8	17.3/20.0	6.0	30/35	30/33
RXBH-24A15J	MULTI CKT 2	208/240	1/60	7.2/9.6	34.6/40.0	0.0	45/50	44/50
RXBH-24A18J	SINGLE	208/240	1/60	12.8/17.0	61.2/70.8	6.0	90/100	84/96
RXBH-24A18J	MULTI CKT 1	208/240	1/60	6.4/8.5	30.8/35.4	6.0	50/60	46/52
RXBH-24A18J	MULTI CKT 2	208/240	1/60	6.4/8.5	30.8/35.4	0.0	40/45	39/45
RXBH-24A20J	SINGLE	208/240	1/60	14.4/19.2	69.2/80.0	6.0	100/110	94/108
RXBH-24A20J	MULTI CKT 1	208/240	1/60	7.2/9.6	34.6/40.0	6.0	60/60	51/58
RXBH-24A20J	MULTI CKT 2	208/240	1/60	7.2/9.6	34.6/40.0	0.0	45/50	44/50
RXBH-24A07C	SINGLE	208/240	3/60	5.4/7.2	15.0/17.3	6.0	30/30	27/30
RXBH-24A10C	SINGLE	208/240	3/60	7.2/9.6	20.0/23.1	6.0	35/40	33/37
RXBH-24A15C	SINGLE	208/240	3/60	10.8/14.4	30.0/34.6	6.0	45/60	45/51
RXBH-24A18C	SINGLE	208/240	3/60	12.4/17.0	35.6/41.0	6.0	60/60	52/59
RXBH-24A18C	MULTI CKT 1	208/240	3/60	6.4/8.5	17.8/20.5	6.0	30/35	30/34
RXBH-24A18C	MULTI CKT 2	208/240	3/60	6.4/8.5	17.8/20.5	0.0	25/30	23/26
RXBH-24A20C	SINGLE	208/240	3/60	14.2/19.2	40.0/46.2	6.0	60/70	58/66
RXBH-24A20C	MULTI CKT 1	208/240	3/60	7.2/9.6	20.0/23.1	6.0	35/40	33/37
RXBH-24A20C	MULTI CKT 2	208/240	3/60	7.2/9.6	20.0/23.1	0.0	25/30	25/29

S = SINGLE CIRCUIT/CIRCUIT SIMPLE M = MULTIPLE CIRCUIT/CIRCUIT MULTIPLE

INDOOR BLOWER MOTOR LOAD INCLUDED IN CIRCUIT # 1 OR TOTAL SUPPLY WIRE MUST BE RATED AT 75°C MINIMUM COPPER CONDUCTORS ONLY. TEST EXTERNAL STATIC RANGE: 1 TO 5 IN. W.C. (HEAT PUMP & ELECTRIC HEAT).

UNITS WITH ELECTRIC HEATERS: CLEARANCE TO COMBUSTIBLE MATERIAL TO BE 0 IN. TO UNIT CASING AND 0 IN. TO PLENUM AND DUCT FOR FIRST 36 IN. MODELS HAVE INTEGRAL CIRCUIT BREAKERS WHICH PROVIDE SUPPLEMENTARY OVERCURRENT PROTECTION AND SERVE AS A MAINTENANCE "DISCONNECT". SUPPLY CIRCUIT NOT TO EXCEED 120 VOLTS TO GROUND ON SINGLE PHASE UNITS. REPLACE LINE SIDE BREAKER COVER(S) AFTER MAKING WIRING CONNECTIONS TO BREAKER(S). IF BLOWER-CONTROL ASSEMBLY REQUIRES REMOVAL, SEE "WARNING HAZARDOUS VOLTAGE".

CHARGEMENT DU MOTEUR SOUFFLEUR INTERNE INCLUS DANS LE CIRCUIT # 1 OU CAPACITÉ DU CÂBLAGE D'ALIMENTATION TOTAL DOIT ÊTRE DE 75C DU MINIMUM DE CONDUCTEURS DE CUIVRE SEULEMENT. TESTER L'INTERVALLE STATIQUE EXTERNE: 1 À 5 PO W.C. (THERMOPOMPE ET CHAUFFAGE ÉLECTRIQUE)

UNITÉS AVEC CHAUFFAGES ÉLECTRIQUES: LE DÉGAGEMENT AUX MATIÈRES COMBUSTIBLES DOIT ÊTRE DE 0 po AU BOITIER DE L'UNITÉ ET DE 0 po AU PLÉNUM ET CONDUIT POUR LES 36 PREMIERS po. LES MODÈLES DISPOSENT DE DISJONCTEURS INTÉGRÉS QUI FOURNISSENT UNE PROTECTION SUPPLÉMENTAIRE DE SURINTENSITÉ DE COURANT ET SERVENT DE « SECTIONNEUR » D'ENTRETIEN. LE CIRCUIT D'ALIMENTATION NE DOIT PAS DÉPASSER 120 VOLTS JUSQU'AU SOL SUR DES UNITÉS MONOPHASÉES. REMPLACER LE(S) COUVERCLE(S) DU DISJONCTEUR DU CÔTÉ SECTEUR APRÈS AVOIR EFFECTUÉ LA CONNEXION DES CÂBLAGES AU(X) DISJONCTEUR(S). SI L'ASSEMBLAGE DE CONTRÔLE DU VENTILATEUR A BESOIN D'ÊTRE DÉASSEMBLÉ, CONSULTER "AVERTISSEMENT DE TENSION DANGEREUSE"

If a heater kit is listed both Single and Multi-circuit, the kit is shipped as a Multi-circuit and will require a single point kit.

Contractor should "mark or check" the left column for the kit installed.

These are the required maximum and minimum circuit breaker sizes for overcurrent protection and should not be confused with the size of the breakers installed in the heater kit.

Only listed kits can be applied

Heater Kit Supplemental Information: What allows the manufacturer to use standard Circuit Breakers up to 60 amps inside the air handler, when using an approved Heater Kit?

National Electric Code (Section 424-22b) and UL standards allow subdividing heating element circuits, of less than 48 amps, using breakers of not more than 60 amps. Additionally per NEC 424-3b, a rating not less than 125 percent of the load and NEC 424-22c, which describes the supplementary overcurrent protection required to be factory-installed within, or on the heater. The breakers in the heater kit are not, and have never been intended to protect power wiring leading to the air handler unit. The breakers in the heating kit are for short circuit protection and to provide a disconnect. All internal unit wiring, where the breakers apply, has been UL approved for short circuit protection.

Ampacity, (not breaker size), determines supply circuit wire size. The ampacity listed on the unit rating plate and the Maximum and Minimum circuit breaker size (noted above) or in the units specification sheet or installation instructions provides the information to properly select wire and circuit breaker/protector size. The National Electric Code (NEC) specifies that the supply or branch circuit must be protected at the source.

3.12.7 ECONET™ COMMUNICATIONS CONTROL

WIRING

The *EcoNet™* (-)H2VZ/(-)H3VZ/(-)HMVZ series of air handlers are designed to operate with conventional 24VAC controls or with an *EcoNet™* communicating system.

For the *EcoNet™* communicating system, you must have:

- Air handler equipped with a *EcoNet™ Control*
- Condensing unit or heat pump equipped with a *EcoNet™ Control*.
- An *EcoNet™ Control Center*

If your equipment does not meet this criteria, you must wire it using conventional 24VAC thermostat control wiring. Reference Section 3.12.9.

EcoNet™ requires four (4) control wires for unit operation:

- R – 24VAC
- C – 24VAC common
- E1 – Data wire 1
- E2 – Data wire 2

Wiring sizing for *EcoNet™ communication* is identical to systems using low voltage 24V wires.

Note: The *EcoNet™ system* requires a minimum 18 AWG.

IMPORTANT: Class 2 low voltage control wire should not be run in conduit with power wiring and must be separated from power wiring, unless Class 1 wire of proper voltage rating is used.

- The four 18AWG low voltage control wires must be installed from the thermostat to the indoor unit and from indoor unit to the outdoor unit. The wire length between the thermostat and indoor unit should not be greater than 100 feet [30 m]. The wire length between the indoor unit and outdoor unit should not be greater than 125 feet [38 m].
- Low voltage control connections are made by routing wires directly to the air handler through knock-outs on top and side of air handler.
- Refer to Figure 14 below for control wiring connections.
- Do not leave excess field control wiring inside unit, pull excess control wire to outside of unit and provide strain relief for field wiring on inside of cabinet at point wiring penetrates cabinet.
- Make sure, after installation, separation of control wiring and power wiring has been maintained.

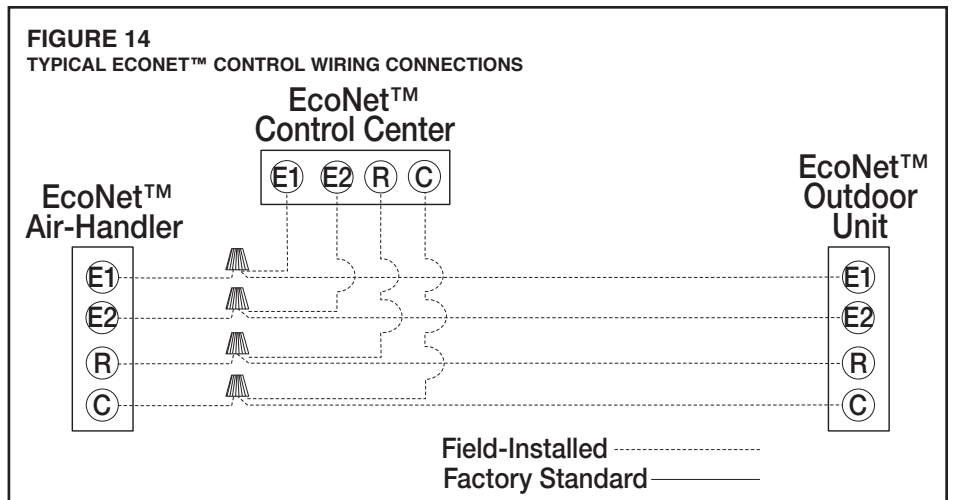

3.12.8 AUXILIARY SWITCH INPUTS

(ECONET™ COMMUNICATING SYSTEMS ONLY – SEE FIGURE 15)

AUX, CS, and C pins on the control board can be used as inputs for field installation of up to two auxiliary switches. The auxiliary inputs are for traditional drain pan switches, drain overflow switches, smoke detectors, freeze switches, etc. The auxiliary switch inputs will only work when the air-handler is wired for *EcoNet™* communication. Using these inputs for communicating systems is superior to wiring the switches in series with the “R” circuit since the *EcoNet™ Control Center* provides multiple response options than simply shutting down the entire system including the *Control Center*. Using the auxiliary inputs will also allow the *Control Center* to display the fault on the screen and can be configured to sound an audible alarm. The auxiliary inputs must be configured at the *EcoNet™ Control Center* as either “normally-open” or “normally closed” contacts. How the system responds to the contacts opening or closing can be configured at the *EcoNet™ Control Center*.

A resistance of greater than 1000 ohms to common will be recognized as an open switch and a resistance of less than 100 ohms will be recognized as a closed switch.

FIGURE 15**WIRING OF AUXILIARY SWITCH INPUTS (USE WITH COMMUNICATING SYSTEMS ONLY)**
WIRING DIAGRAM - OPTIONAL AUXILIARY INPUTS

NOTE: AUXILIARY INPUTS ARE ONLY MONITORED IN COMMUNICATING MODE.

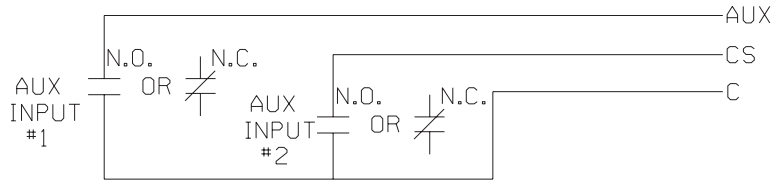

NOTE: EITHER A NORMALLY-OPENED (N.O.) OR NORMALLY-CLOSED (N.C.) ACCESSORY CAN BE ATTACHED TO AUXILIARY INPUTS 1 AND/OR 2. SELECT CONFIGURATION (N.O. OR N.C.) AT THE ECONET™ CONTROL CENTER.

3.12.9 CONVENTIONAL 24VAC THERMOSTAT CONTROL WIRING

The (-)H2VZ/(-)H3VZ/(-)HMVZ-series air-handlers and (-)A13, (-)A14, (-)A15, (-)A16, (-)A18, (-)P14, (-)P15, (-)P16, and (-)P18-series of outdoor units allow the installer to use conventional 24VAC control wiring and a conventional single-stage or two-stage cooling thermostat for unit operation. (-)A18 condensing units and (-)P18 heat pumps operate in single-stage mode at nominal capacity when being controlled by a conventional 24VAC thermostat which requires the Y1 and Y2 on the air-handler to be wired together to assure full air-flow.

IMPORTANT: The preferred method of unit installation and operation is by the EcoNet™ Communicating System, which allows access to the fault history of the system. This diagnostic information is not available when the (-)A18/(-)P18 unit is using a conventional thermostat. Reference section 3.12.8, EcoNet™ Control Wiring.

Thermostat control wiring requires a minimum of seven (7) wires for proper unit operation:

- R – 24VAC
- C – 24VAC common
- G – Constant Fan
- W1 – First stage electric heat
- W2 – Second stage electric heat
- Y1 – First stage operation
- Y2 – Second stage operation

Optional wiring:

- ODD – On demand humidification

NOTE: W1 and W2 may be jumpered together to energize all the electric heat when a call for electric heat is received if warmer supply air is desired.

NOTE: When using 24VAC thermostat control wiring, the serial communicating control will ignore any inputs to Data wire 1 and Data wire 2.

IMPORTANT: Class 2 low voltage control wire should not be run in conduit with power wiring and must be separated from power wiring, unless Class 1 wire of proper voltage rating is used.

Low voltage control wiring should be 18 AWG color-coded (105°C minimum). For lengths longer than 100 ft. [30 m], 16 AWG wire should be used.

Low voltage control connections are made at the thermostat pigtails extending wires from top of air handler using wire nuts. The thermostat pigtails can be rerouted through 5/8" [15.8 mm] or 7/8" [22.2 mm] diameter knock-outs located on each side of the air-handler cabinet for applications where the top exit is not suitable.

See wiring diagrams attached to indoor and outdoor sections to be connected.

Do not leave excess field control wiring inside unit, pull excess control wire to outside of unit and provide strain relief for field wiring on inside of cabinet where wiring penetrates cabinet.

Make sure, after installation, separation of control wiring and power wiring has been maintained.

See Section 3.12.1 for 208 volt applications.

3.12.10 CONVENTIONAL 24VAC THERMOSTAT CONTROL WIRING CONNECTION DIAGRAMS

The low voltage application diagrams shown in Figures 16-22 below are specific to (-)A13, (-)A14, (-)A15, (-)A16, (-)A18, (-)P14, (-)P15, (-)P16, and (-)P18 series outdoor units. If connecting this air-handler to other models, there may be differences in how the outdoor units are to be connected and will require referencing the outdoor unit manufacturer's installation instructions for connecting control wiring to that specific model.

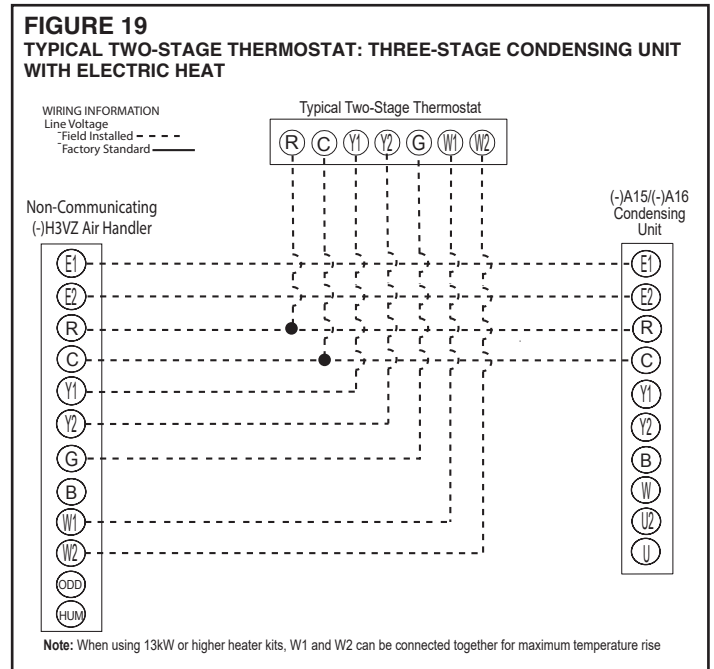
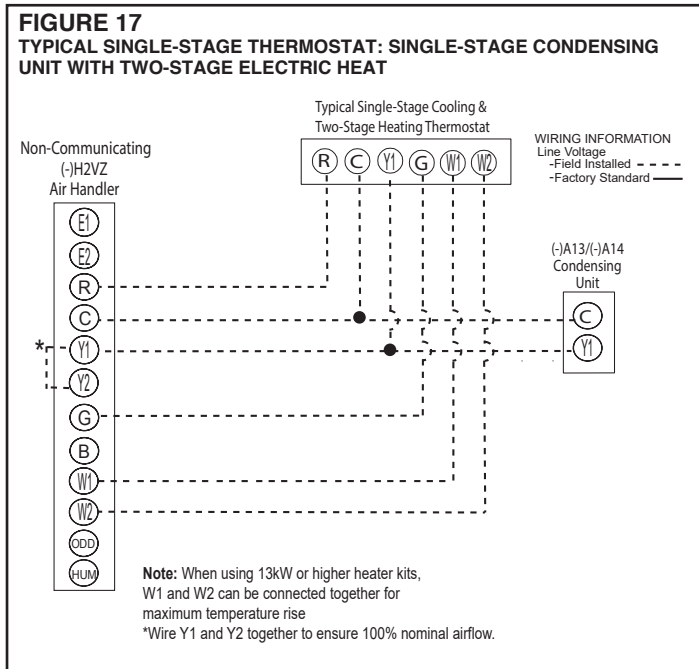
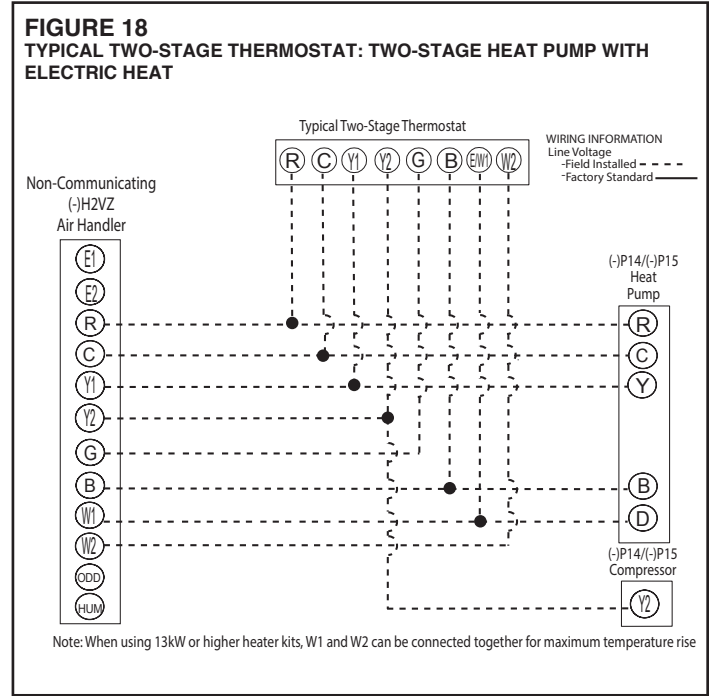
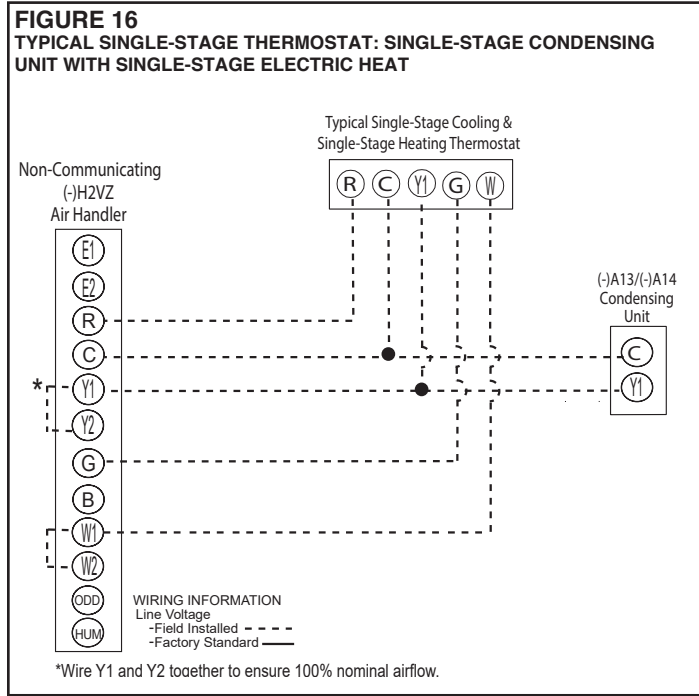

3.12.10 CONVENTIONAL 24VAC THERMOSTAT CONTROL WIRING CONNECTION DIAGRAMS – continued

FIGURE 20
TYPICAL TWO-STAGE THERMOSTAT: THREE-STAGE HEAT PUMP WITH ELECTRIC HEAT

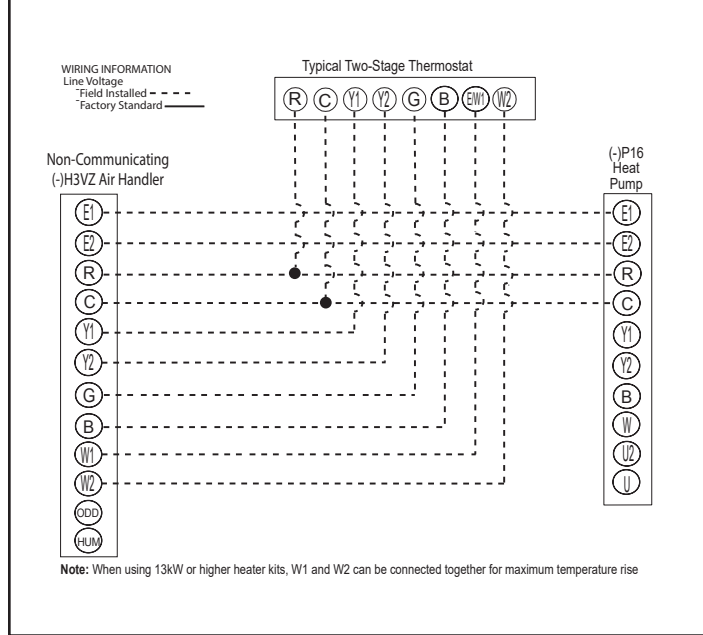

FIGURE 22
TYPICAL SINGLE-STAGE THERMOSTAT: 'EMERGENCY MODE' VARIABLE SPEED HEAT PUMP OPERATING AS SINGLE-STAGE WITH ELECTRIC HEAT

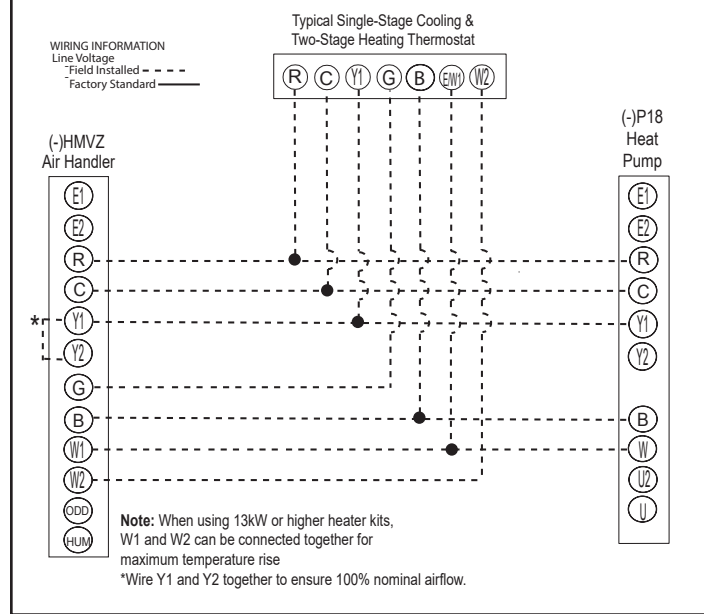
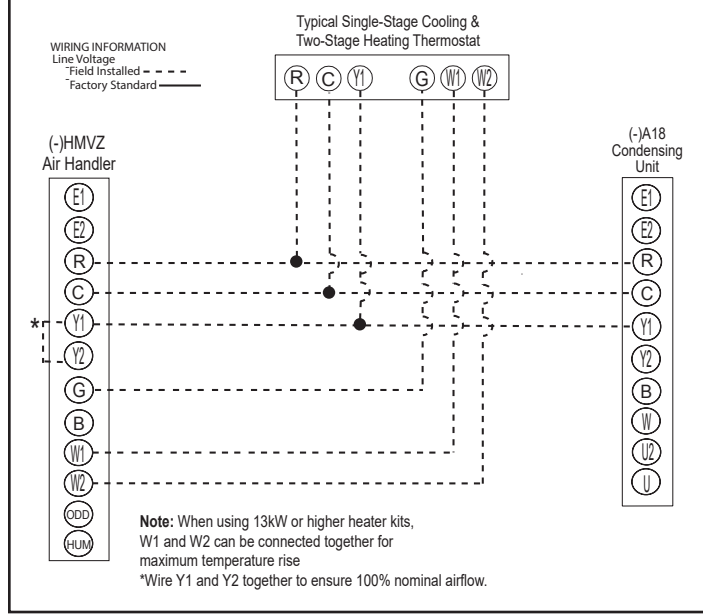

FIGURE 21
TYPICAL SINGLE-STAGE THERMOSTAT: 'EMERGENCY MODE' VARIABLE SPEED CONDENSING UNIT OPERATING AS SINGLE-STAGE WITH ELECTRIC HEAT



3.13 AIR-FLOW

3.13.1 (-)H2VZ/(-)H3VZ/(-)HMVZ AIR-FLOW

SETTINGS OVERVIEW

(-)H2VZ/(-)H3VZ/(-)HMVZ air-handlers have variable speed electronically commutated motors (ECM) which deliver an optimum level of air-flow for multi-stage or variable speed system operation over a wide range of external static pressures up to 1.0" W.C. [0.24 kPa]. The air-flow level varies based on the percentage of full capacity the multi-stage or variable speed outdoor unit is operating at, dehumidification requirements, and if the electric heat is energized. When connected in the EcoNet™ communicating mode using the EcoNet™ Control Center and a matching EcoNet™ enabled outdoor unit, the air-flow is automatically set to the appropriate level based on the outdoor unit connected to the system. When connected to a conventional 24VAC thermostat, air-flow settings must be manually configured in the field using the BlueTooth Contractor App to assure proper air-flow is delivered for the particular system being installed. It is also possible to configure the available dehumidification options using the menu in the EcoNet™ Control Center or using the BlueTooth Contractor App should enhanced dehumidification be desired.

TABLE 1

Rated Air-Flow for (-)H2VZ Air-Handlers + (-)A13/(-)A14 Condensing Units & (-)P14/(-)P15 Heat Pumps

Air-Handler Model	Outdoor Model	(-)H2VZ Air-Flow (EcoNet™)*			
		Cooling Mode CFM [L/s]		Heating Mode CFM [L/s]	
		Minimum	Maximum	Minimum	Maximum
(-)H2VZ2417STANN	(-)A13NZ18/(-)A13NZ24	580 [274]	767 [362]	-	-
	(-)A14AZ18/(-)A14AZ24			-	-
	(-)P14AZ18/(-)P14AZ24			580 [274]	767 [362]
	(-)P15AZ18/(-)P15AZ24				
(-)H2VZ3617STANN	(-)A13NZ30/(-)A13NZ36	727 [343]	1069 [505]	-	-
	(-)A14AZ30/(-)A14AZ36			-	-
	(-)P14AZ30/(-)P14AZ36			727 [343]	1069 [505]
	(-)P15AZ30/(-)P15AZ36				
(-)H2VZ3621STANN	(-)A13NZ30/(-)A13NZ36	727 [343]	1069 [505]	-	-
	(-)A14AZ30/(-)A14AZ36			-	-
	(-)P14AZ30/(-)P14AZ36			727 [343]	1069 [505]
	(-)P15AZ30/(-)P15AZ36				
(-)H2VZ3621MTANN	(-)A13NZ30/(-)A13NZ36	727 [343]	1069 [505]	-	-
	(-)A14AZ30/(-)A14AZ36			-	-
(-)H2VZ3621MTANA	(-)A13NZ30/(-)A13NZ36	727 [343]	1069 [505]	-	-
	(-)A14AZ30/(-)A14AZ36			-	-
(-)H2VZ4821STANN	(-)A13NZ42/(-)A13NZ48	1024 [483]	1478 [698]	-	-
	(-)A14AZ42/(-)A14AZ48			-	-
	(-)P14AZ42/(-)P14AZ48			1024 [483]	1478 [698]
	(-)P15AZ42/(-)P15AZ48				
(-)H2VZ4821STANA	(-)A13NZ42/(-)A13NZ48	1024 [483]	1478 [698]	-	-
	(-)A14AZ42/(-)A14AZ48			-	-
(-)H2VZ4824STANN	(-)A13NZ42/(-)A13NZ48	1024 [483]	1478 [698]	-	-
	(-)A14AZ42/(-)A14AZ48			-	-
	(-)P14AZ42/(-)P14AZ48			1024 [483]	1478 [698]
	(-)P15AZ42/(-)P15AZ48				
(-)H2VZ6021STANA	(-)A13NZ60/(-)A13NZ60	1140 [538]	1857 [876]	-	-
(-)H2VZ6024STANN	(-)A13NZ60/(-)A13NZ60	1140 [538]	1857 [876]	-	-
	(-)P14AZ60/(-)P15AZ60			1140 [538]	1857 [876]

*When using an EcoNet Control Center, the air handler will deliver 375 CFM/ton.

TABLE 2

Rated Air-Flow for (-)H3VZ Air-Handlers + (-)A15/(-)A16 Condensing Units & (-)P16 Heat Pumps

Air-Handler Model	Outdoor Model	(-)H3VZ Air-Flow (EcoNet™)			
		Cooling Mode CFM [L/s]		Heating Mode CFM [L/s]	
		Minimum	Maximum	Minimum	Maximum
(-)H3VZ2417STA(-)N	(-)A15AZ24	340 [160]	750 [354]	-	-
	(-)A16AZ24	340 [160]	750 [354]	-	-
	(-)P16AZ24	360 [170]	750 [354]	360 [170]	750 [354]
(-)H3VZ3617STA(-)N	(-)A15AZ36	500 [236]	1125 [531]	-	-
	(-)A16AZ36	500 [236]	1125 [531]	-	-
	(-)P16AZ36	500 [236]	1125 [531]	500 [236]	1125 [531]
(-)H3VZ4821STA(-)N	(-)A15AZ48	650 [307]	1450 [684]	-	-
	(-)A16AZ48	650 [307]	1450 [684]	-	-
	(-)P16AZ48	650 [307]	1450 [684]	650 [307]	1450 [684]
(-)H3VZ6024STA(-)N	(-)A15AZ60	810 [382]	1800 [850]	-	-
	(-)A16AZ60	810 [382]	1800 [850]	-	-
	(-)P16AZ60	810 [382]	1800 [850]	810 [382]	1800 [850]
(-)H3VZ2417MTA(-)N	(-)D17AZ24	420 [198]	760 [358]	530 [250]	760 [358]
(-)H3VZ3621MTA(-)N	(-)D17AZ36	640 [302]	1060 [500]	640 [302]	1060 [500]
(-)H3VZ4824STA(-)N	(-)D17AZ48	930 [438]	1430 [674]	1200 [566]	1430 [674]
(-)H3VZ6024STA(-)N	(-)D17AZ60	900 [424]	1800 [850]	1345 [634]	1800 [850]

TABLE 3

Rated Air-Flow for (-)HMVZ Air-Handlers + (-)A18 Condensing Units & (-)P18 Heat Pumps

Air-Handler Model	Outdoor Model	(-)HMVZ Air-Flow (EcoNet™)			
		Cooling Mode CFM [L/s]		Heating Mode CFM [L/s]	
		Minimum	Maximum	Minimum	Maximum
(-)HMVZ2417SEACN	(-)A18AZ24	310 [146]	840 [396]	-	-
(-)HMVZ2421MEACN	(-)A18AZ24	310 [146]	840 [396]	-	-
(-)HMVZ2421HEACN	(-)A18AZ24	310 [146]	840 [396]	-	-
(-)HMVZ2421HEACA	(-)P18AZ24	500 [236]	800 [378]	600 [283]	800 [378]
(-)HMVZ6021SEACA	(-)A18AZ36	580 [274]	1210 [571]	-	-
	(-)A18AZ48	475 [224]	1565 [739]	-	-
	(-)A18AZ60	516 [244]	1725 [814]	-	-
	(-)P18AZ36	516 [244]	1200 [566]	960 [453]	1300 [614]
	(-)P18AZ48	550 [260]	1600 [755]	950 [448]	1500 [708]
(-)HMVZ6024SEACN	(-)P18AZ60	1100 [519]	1700 [802]	1100 [519]	1800 [850]
	(-)A18AZ36	580 [274]	1210 [571]	-	-
	(-)A18AZ48	475 [224]	1565 [739]	-	-
	(-)A18AZ60	516 [244]	1725 [814]	-	-

3.13.2 (-)H2VZ/(-)H3VZ/(-)HMVZ COOLING & HEAT PUMP HEATING AIR-FLOW SETTINGS

Cooling and heat pump heating air-flow is automatically set when the EcoNet™ enabled (-)H2VZ, (-)H3VZ, and (-)HMVZ air-handlers are connected to an EcoNet™ Control Center and EcoNet™ enabled outdoor unit per Section 3.12.7 (EcoNet™ Communications Control Wiring) as long as the outdoor unit is approved by the manufacturer for use with the particular air-handler being installed. The (-)H2VZ, (-)H3VZ, and (-)HMVZ air-handler detects the model of the outdoor unit via the EcoNet™ communications and sets the air-flow characteristics for optimum performance and comfort. Refer to Tables 1-3 for the air-flow levels when connected to the approved EcoNet™ enabled outdoor models. If desired, the cooling air-flow may be adjusted by +20/-25% using the

Cooling Air-Flow Trim Adjustment menu in the EcoNet™ Control Center.

When an (-)HMVZ air-handler is matched with a variable speed (-)A18 or (-)P18 Series outdoor unit in the EcoNet™ communicating mode, the air-flow will vary based on the percentage capacity the inverter is driving the compressor, so the actual air-flow may be anywhere between the minimum and maximum air-flow at any given point in time.

When a conventional 24VAC thermostat is used with an (-)H2VZ/(-)H3VZ/(-)HMVZ air-handler, the air-flow must be set manually using the BlueTooth Contractor App. In the instance an (-)H2VZ/(-)H3VZ/(-)HMVZ air-handler is paired with a non-communicating outdoor and an EcoNet Control Center is present, airflow will be set to a minimum of 375 CFM per ton.

IMPORTANT: Matching non-approved combinations in 24VAC thermostat applications will result in unsatisfactory operation of the system.

TABLE 4
(-)H2VZ/(-)H3VZ/(-)HMVZ Air handler and electric heater kit compatibility

Heater Size (kW)	(-)H2VZ/(-)H3VZ/(-)HMVZ Air Handler Models								
	2417	2421	3021	2417M/3617	3621	3621M/4821	4824	6021	4824S/6024
3	YES	YES	YES	YES	YES	YES	YES	YES	YES
5	YES	YES	YES	YES	YES	YES	YES	YES	YES
7	YES	YES	YES	YES	YES	YES	YES	YES	YES
10	YES	YES	YES	YES	YES	YES	YES	YES	YES
13	YES	YES	YES	YES	YES	YES	YES	YES	YES
15	-	-	YES	YES	YES	YES	YES	YES	YES
18	-	-	YES	YES	YES	YES	YES	YES	YES
20	-	-	-	-	-	YES	YES	YES	YES
25	-	-	-	-	-	YES	YES	YES	YES
30	-	-	-	-	-	YES	YES	YES	YES

Note: For heater kit part numbers, refer to 3.12.5 electrical data

3.13.3 (-)H2VZ/(-)H3VZ/(-)HMVZ ELECTRIC HEAT AIR-FLOW SETTINGS

(-)H2VZ/(-)H3VZ/(-)HMVZ air-handlers are shipped from the factory to deliver adequate air-flow for the maximum allowed electric heat kW (see Table 4 below). The control board on the air-handler automatically detects the unique resistance of each heater kit and adjusts air-flow accordingly.

3.13.4 (-)H2VZ/(-)H3VZ/(-)HMVZ COOLING MODE

Normal Humidity	Result
A 24VAC signal is applied to the ODD terminal	Full rated airflow is delivered by the blower

DEHUMIDIFICATION

High Humidity	Result
No signal (0 VAC) applied to the ODD terminal	Airflow is reduced by 15% to increase latent capacity

On Demand Dehumidification (ODD) is accessible via the EcoNet Control Center or via the BlueTooth Contractor app. Refer to their instructions to access the ODD airflow adjustment menu. ODD operation is controlled by the indoor humidity sensed at the **EcoNet™ Control Center**, dehumidifying thermostat, or humidistat. Operation is:

Normal Humidity (humidity BELOW the humidity set point):

High Humidity (humidity ABOVE the humidity set point):

IMPORTANT: Only humidistats with contacts that open when the humidity level in the conditioned space is above the humidity set-point can be used. Only dehumidifying thermostats that energize the DHM terminal when the humidity in the conditioned space is below the humidity set-point can be used.

NOTE: ODD airflow adjustments are active for cooling operation only. They are ignored when the heat pump is in the heating mode or anytime electric heat is activated.

4.0 START-UP

4.1 PRE-START CHECKLIST

PRE-START CHECKLIST	
<input type="checkbox"/> YES <input type="checkbox"/> NO	Is unit properly located, level, secure and serviceable?
<input type="checkbox"/> YES <input type="checkbox"/> NO	Has auxiliary pan been provided under the unit with separate drain? (Units installed above a finished ceiling).
<input type="checkbox"/> YES <input type="checkbox"/> NO	Is condensate line properly sized, run, trapped, pitched and tested?
<input type="checkbox"/> YES <input type="checkbox"/> NO	Is ductwork correctly sized, run, taped and insulated?
<input type="checkbox"/> YES <input type="checkbox"/> NO	Have all cabinet openings and wiring been sealed with caulking?
<input type="checkbox"/> YES <input type="checkbox"/> NO	Is the filter clean, in place and of adequate size?
<input type="checkbox"/> YES <input type="checkbox"/> NO	Is the wiring tight, correct and to the wiring diagram?
<input type="checkbox"/> YES <input type="checkbox"/> NO	Is the unit properly grounded and protected (fused)?
<input type="checkbox"/> YES <input type="checkbox"/> NO	Is the thermostat heat anticipator set properly?
<input type="checkbox"/> YES <input type="checkbox"/> NO	Is the unit circuit breaker(s) rotated properly "on" up - "off" down?
<input type="checkbox"/> YES <input type="checkbox"/> NO	Are the unit circuit breaker(s) line lug cover(s) in place?
<input type="checkbox"/> YES <input type="checkbox"/> NO	Are all access panels in place and secure?

Refer to outdoor unit installation instructions for system start-up instructions and refrigerant charging instructions.

4.2 SYSTEM START-UP AND OPERATIONAL CHECK-OUT

After the air-handler and other system components have been installed and the Pre-Start Checklist has been completed, the system should be started up and an operational check-out should be performed. The operational check-out includes checking sequence of operation of the controls, air-flow, and refrigerant charge. If the controls are not found to be functioning properly, or the air-flow or refrigerant charge are not within specifications, corrective action must be taken. The following sections are provided to assist the installer with the operational check-out.

4.3 SEQUENCE OF OPERATION

4.3.1 COOLING MODE: (-)H2VZ/(-)H3VZ

When wired for EcoNet™ communications, the EcoNet™ Control Center will select which stage of cooling is necessary and will then communicate this information to the EcoNet™ Air-Handler Control Board. The control board will then communicate with the variable speed ECM motor and EcoNet™ enabled outdoor unit to direct the motor to start and operate cooling air-flow level based on the CFM call from the outdoor model data. When the call for cooling has ended, the control board will direct the motor to operate at the minimum air-flow level for 45 seconds to extract the residual cooling from the cold indoor coil before it directs the motor to stop.

4.3.1.1 COOLING MODE: (-)H2VZ WITH 24VAC SINGLE-STAGE THERMOSTAT

When a conventional 24VAC single-stage thermostat calls for cooling, Y1 and Y2 terminals must be jumped on the (-)H2VZ Air-Handler Control Board to ensure 100% nominal air flow. The Air-Handler Control Board communicates with the variable speed ECM motor to operate at maximum cooling air-flow. When the call for cooling has ended, the control board will direct the motor to continue to operate for 45 seconds to extract the residual cooling from the cold indoor coil before it directs the motor to stop.

4.3.1.2 COOLING MODE: (-)H2VZ WITH 24VAC TWO-STAGE THERMOSTAT

When a conventional 24VAC two-stage thermostat calls for first-stage cooling, the (-) H2VZ Air-Handler Control Board communicates with the variable speed ECM motor to operate at first-stage cooling air-flow. The first-stage cooling call also causes the (-) P14/(-)P15 outdoor unit to jump to its first-stage capacity. If the thermostat calls for second-stage cooling, the control board will communicate with the blower motor to operate at second-stage air-flow levels. The (-)P14/(-)P15 outdoor unit will also operate at its second-stage capacity. When the call for cooling has ended, the control board will direct the motor to operate at the minimum air-flow level for 45 seconds to extract the residual cooling from the cold indoor coil before it directs the motor to stop.

4.3.1.3 COOLING MODE: (-)H3VZ WITH 24VAC TWO-STAGE THERMOSTAT

When a conventional 24VAC two-stage thermostat calls for first-stage cooling, the (-) H3VZ Air-Handler Control Board communicates with the variable speed ECM blower motor to operate at first-stage cooling air-flow. The first-stage cooling call also causes the (-)A15/(-)A16/(-)P16 outdoor unit to jump to 45% capacity within 30 seconds. The system will continue to operate at 45% capacity until the adaptive learning algorithm stored in the Universal Outdoor Controller determines (based on past run history) when to move the system into an intermediate stage at 65% capacity. The adaptive learning algorithm records how the system ran at intermediate speeds previously and adapts current cycle. When the thermostat calls for second-stage cooling, the air-handler control board will communicate with the blower motor to operate at the maximum air-flow level. The outdoor unit will also jump to its maximum capacity. When the call for cooling has ended, the air-handler control board will direct the blower motor to operate at the minimum air-flow level for 45 seconds to extract the residual cooling from the cold indoor coil before it directs the blower motor to stop. The universal outdoor controller has a five minute off-delay. Once the outdoor unit is de-energized, it will require 5 minutes before it can be restarted.

4.3.2 COOLING MODE: (-)H MVZ

When wired for EcoNet™ communications, the EcoNet™ Control Center will determine when cooling is necessary and the percentage of capacity required and will then communicate this information to the EcoNet™ Air-Handler Control Board. The control board will then communicate with the variable speed ECM motor and EcoNet™ enabled outdoor unit to direct the motor to start and operate at the appropriate cooling air-flow level based on the outdoor unit model and the percentage capacity the outdoor unit is operating at throughout the call for cooling. The air-flow level will vary as required. When the call for cooling has ended, the control board will direct the motor to operate at the minimum air-flow level for 45 seconds to extract the residual cooling from the cold indoor coil before it directs the motor to stop.

4.3.2.1 (-)H MVZ WITH 24 VAC SINGLE-STAGE THERMOSTAT (EMERGENCY MODE)

When a conventional 24VAC single-stage thermostat calls for cooling, Y1 and Y2 terminals must be jumped on the (-)H MVZ Air-Handler Control Board to ensure 100% nominal air flow. The Air-Handler Control Board communicates with the variable speed ECM motor to operate at maximum cooling air-flow. The (-)A18/(-)P18 outdoor unit will also ramp up to its maximum capacity. When the call for cooling has ended, the control board will direct the motor to continue to operate for 45 seconds to extract the residual cooling from the cold indoor coil before it directs the motor to stop.

4.3.3 ELECTRIC HEAT MODE: (-)H2VZ/(-)H3VZ/(-)H MVZ

When the EcoNet™ Control Center or conventional 24VAC 2-stage thermostat calls for the 1st stage of electric heat, the EcoNet™ Air-Handler Control Board will communicate to the variable speed ECM motor to ramp up the electric heat air-flow level. The motor will ramp up to speed over a 15 second period. The control board will also energize all of the electric heater elements for heater kits with 10kW of heat or less and the 1st stage elements for 13kW heater kits and higher. If the EcoNet™ Control Center or 2-stage thermostat calls for a 2nd stage of electric heat when a 13kW or higher heater kit is installed, the 2nd stage of electric heat will be energized. The electric heater will cycle between the 1st and 2nd stages of heat at the direction of the EcoNet™ Control Center or thermostat. When the call for heat is satisfied, the heating elements will be de-energized in approximately one minute when the bimetallic disc sequencer relays in the heater assembly cool down and their contacts open. The motor will be de-energized 75 seconds after the call for electric heat ends to allow time for the heating elements to cycle off.

4.3.4 HEAT PUMP HEATING MODE: (-)H2VZ/(-)H3VZ

When wired for EcoNet™ communications, the EcoNet™ Control Center will determine which stage of heating is necessary and will then communicate this information to the EcoNet™ Air-Handler Control Board. The control board will then communicate with the variable speed ECM motor and EcoNet™ enabled outdoor unit to direct the motor to start and operate at heating air-flow level based on the model data stored on the Econet Universal Outdoor Control in the outdoor unit. Upon a call for 1st stage heating, the EcoNet™ Air-Handler Control Board communicates with the variable speed ECM motor

to operate at the 1st stage air-flow level. If the EcoNet™ Control Center calls for 2nd stage heating, the EcoNet™ Air-Handler Control Board will communicate with the motor to ramp up to the appropriate air-flow level.

When the call for heating has ended, the Control Board will direct the motor to operate at the minimum air-flow level for 45 seconds to extract the residual cooling from the cold indoor coil before it directs the motor to stop.

When a conventional 24VAC 2-stage thermostat calls for 1st stage heating, the EcoNet™ Air-Handler Control Board communicates with the variable speed ECM motor to operate at the appropriate air-flow level set using the heating air-flow from the EcoNet Control Board Model Data. If the thermostat calls for 2nd stage heating, the control board will communicate with the motor to ramp up to the 2nd stage air-flow level. When the call for heating has ended, the control board will direct the motor to operate at the minimum air-flow level for 45 seconds to extract the residual heat from the warm indoor coil before it directs the motor to stop.

NOTE: If supplemental electric heat is energized during the heat pump heating mode, the electric heat air-flow setting will override the heat pump heating air-flow setting and the indoor air-flow will go to the CFM [L/s] selected in the EcoNet™ Control Center, or for 24VAC thermostat applications, the CFM [L/s] selected by the air-handler control board.

4.3.5 HEAT PUMP HEATING MODE: (-)HMVZ

When wired for EcoNet™ communications, the EcoNet™ Control Center will determine when heating is necessary and the percentage of capacity required and will then communicate this information to the EcoNet™ Air-Handler Control Board. The control board will then communicate with the variable speed ECM motor and EcoNet™ enabled outdoor unit to direct the motor to start and operate at the appropriate heating air-flow level based on the outdoor unit model and the percentage capacity the outdoor unit is operating at throughout the call for heating. The air-flow level will vary as required. When the call for heating has ended, the control board will direct the motor to operate at the minimum air-flow level for 45 seconds to extract the residual heat from the warm indoor coil before it directs the motor to stop.

When a conventional 24VAC 2-stage heat pump thermostat calls for 1st stage heat, the EcoNet™ Air-Handler Control Board communicates with the variable speed ECM motor to operate at minimum heat pump heating air-flow level set using the heat pump heating air-flow. Since the thermostat energizes the B input on the control board with 24 volts, the control board knows to direct the motor to operate at the heating air-flow levels selected. After 15 minutes of operation at the minimum air-flow level, the control board communicates with the motor to automatically ramp up to intermediate air-flow and will continue to operate at the intermediate air-flow level as long as the 1st stage call is present. The outdoor heat pump unit will also automatically ramp up to its intermediate capacity after 15 minutes of a continuous 1st stage call for heat. If the thermostat calls for 2nd stage heat, the control board will communicate with the motor to ramp up to the maximum air-flow level and the outdoor unit will ramp up to its maximum capacity. As the 2-stage thermostat cycles between the 1st and 2nd stages, the motor and will cycle between the intermediate and maximum air-flow levels as directed by the control board while the outdoor unit cycles between its intermediate and maximum capacity. When the call for cooling has ended, the control board will direct the motor to operate at the minimum air-flow level for 45 seconds to extract the residual heat from the warm indoor coil before it directs the motor to stop.

NOTE: If supplemental electric heat is energized during the heat pump heating mode, the electric heat air-flow setting will override the heat pump heating air-flow setting and the indoor air-flow will go to the CFM [L/s] selected in the EcoNet™ Control Center, or for 24VAC thermostat applications, the CFM [L/s] selected by the air-handler control board.

4.3.6 SUPPLEMENTAL ELECTRIC HEAT DURING DEFROST (HEAT PUMP)

Supplemental electric heat is provided during the defrost cycle to prevent cold air from being discharged from the supply registers in the home. For systems wired for EcoNet™ communications, this is automatic and no action is required during installation and set-up. For conventional 24VAC thermostat applications, a wire must be run from the W terminal on the EcoNet™ Control Board on the heat pump outdoor unit to the W1 thermostat on the air-handler should this feature be desired.

4.3.7 EMERGENCY HEAT (HEAT PUMP)

If the EcoNet™ Control Center is set to the “Emergency Heat” mode, the outdoor unit will be prevented from operating and heat will be supplied solely by the electric heater as described in Sections 4.3.3 above. The electric heating elements will be energized anytime there is a call for heat and the compressor and outdoor fan motor will remain off. For 24VAC thermostat applications, a jumper should be added between the W1 and E terminals on the thermostat sub-base so the electric heat control will be transferred to the 1st stage of electric heat. This doesn’t apply for thermostats where the W1 and E are combined into a single terminal.

4.3.8 THERMOSTAT FAN SETTING

If the EcoNet™ Control Center or thermostat FAN setting is adjusted to the AUTO position, the indoor blower motor will only operate when there is a call for cooling or heating. If the setting is adjusted to the ON position, the indoor blower will continue to circulate air when there is no call for cooling or heating. For (-)H2VZ/(-)H3VZ/(-)HMVZ air-handlers controlled by an EcoNet™ Control Center, the continuous fan speed can be adjusted in the Fan Only menu to OFF or one of 5 available speeds. Refer to the EcoNet™ Control Center users guide for details.

4.4 CORRECTING ELECTRIC HEAT kW FOR VOLTAGE

The actual electric heat kW varies with the supply voltage. Use the following formula to correct the heater rated kW at voltages other than rated voltage.

$$\text{Actual kW} = \text{Rated kW} \times (\text{Actual Voltage}^2 / \text{Rated Voltage}^2).$$

4.5 CALCULATING ELECTRIC HEAT CAPACITY IN BTU/HR

Use the following formula to convert heater kW to heating capacity in BTUH.

$$\text{BTUH Capacity} = \text{kW} \times 3413$$

(Where 3413 = BTUH per kW)

4.5.1 ESTIMATING AIR-FLOW USING ELECTRIC HEAT TEMPERATURE RISE

If the air-handler is equipped with an electric heater, the CFM [L/s] can be estimated using the air temperature rise across the air-handler with the heater and blower both energized once the unit has run long enough for the temperatures to stabilize. As with determining CFM [L/s] using external static pressure, the CFM [L/s] determined by this method is an estimate, but is accurate enough for all practical purposes. Measure the return air temperature as close to the unit as possible and the supply air temperature about half way from the air-handler to the first elbow or end of the supply plenum. Use the following formulas to calculate CFM or L/s once the temperature rise is determined.

$$\text{CFM} = (\text{Heating kW} \times 3413) / (\text{SHC} \times \text{Temp Rise } ^\circ\text{F})$$

$$\text{L/s} = (\text{Heating kW} \times 895) / (\text{SHC} \times \text{Temp Rise } ^\circ\text{C})$$

ALTITUDE FT. [M]	SENSIBLE HEAT CONSTANT (SHC)	ALTITUDE FT. [M]	SENSIBLE HEAT CONSTANT (SHC)
Sea Level	1.08	6000 [1829]	0.87
500 [152]	1.07	7000 [2134]	0.84
1000 [305]	1.05	8000 [2438]	0.81
2000 [610]	1.01	9000 [2743]	0.78
3000 [914]	0.97	10000 [3048]	0.75
4000 [1219]	0.94	15000 [4572]	0.61
5000 [1524]	0.90	20000 [6096]	0.50

4.6 CHECKING REFRIGERANT CHARGE

System refrigerant charging should only be performed after the indoor air-flow is confirmed to be correct for the application. Once the air-flow is confirmed, refer to the manufacturer's outdoor unit charging chart and installation manual for the proper charging procedure for the system.

5.0 COMPONENTS & CONTROLS

5.1 ECONET™ AIR-HANDLER CONTROL BOARD

The EcoNet™ Air-Handler Control Board controls the indoor blower motor & electric heat operation based on inputs from the indoor EcoNet™ Control Center or a conventional room thermostat and humidistat. When wired for EcoNet™ communications connected to an EcoNet™ Control Center and an EcoNet™ enabled outdoor unit, the control board automatically configures itself to deliver the correct indoor air-flow profile for the specific outdoor unit connected to the EcoNet™ network as long as the outdoor unit is an approved match for the air-handler. Also, certain operating characteristics can be configured through the EcoNet™ Control Center. Refer to the EcoNet™ Control Center manual for further details on configurable options that are available. If a conventional 24VAC thermostat is used to control the system, the control board can be manually configured using the BlueTooth Contractor App.

The control board is located inside the control box that is attached to the blower housing. The same control board is used on EcoNet™ enabled (-)H2VZ, (-)H3VZ, (-)HMVZ air-handlers.

The EcoNet™ Air-Handler Control Board has the following features.

- An on-board 5 amp automotive style fuse to protect the control circuit.
- An RJ-14 port for use with a diagnostic tool.
- Constant air-flow for the communicating variable speed ECM motor in (-)H2VZ, (-)H3VZ, and (-)HMVZ.
- Operating outputs for the electronic expansion valve (EXV) used in the (-)HMVZ air-handler.
- Inputs for the factory installed vapor line temperature sensor and pressure transducer for control of the electronic expansion valve (EXV) used in the (-)HMVZ air-handler.
- Inputs for field installed supply and return air temperature sensors available in accessory kit RXHT-A02.
- When the (-)H2VZ, (-)H3VZ, (-)HMVZ air-handler is wired for EcoNet™ communications by connecting to an EcoNet™ Control Center and EcoNet™ enabled outdoor unit, the EcoNet™ Air-Handler Control Board will direct the indoor motor to operate at the correct air-flow for the outdoor unit that is connected to the EcoNet™ network. For variable speed outdoor units, the air-flow level will vary based on the percentage of full capacity the compressor is operating at.
- When the (-)H2VZ, (-)H3VZ, (-)HMVZ air-handlers are being controlled by a conventional 2-stage 24VAC thermostat, the EcoNet™ Control Center will direct the indoor motor to operate at the predetermined airflow levels.
- EcoNet™ Air-Handler Control Board will direct the indoor motor in (-)H2VZ, (-)H3VZ, (-)HMVZ air-handlers to operate at 15% less air-flow if cooling mode dehumidification is enabled and dehumidification is being called for by the EcoNet™ Control Center, a dehumidifying thermostat, or humidistat.
- A call for electric heat will cause the control board to override the heat pump heating air-flow and will direct the indoor motor to operate at the selected electric heat air-flow level.
- A plug on the electric heater kit wiring harness plugs into a 4 pin plug receptacle on the control board to allow control of the electric heater by the control board based on thermostat input.
- There is a 45 second off-delay programmed into the control board when an (-)H2VZ, (-)H3VZ, (-)HMVZ air-handler has been operating in the cooling or heat pump heating mode. The off-delay maximizes efficiency by extracting the residual cooling or heating capacity in the coil.
- There is a 75 second off-delay is programmed into the control board when an (-)H2VZ, (-)H3VZ, and (-)HMVZ air-handler has been operating in the electric heat or emergency heat mode. The off-delay allows time for the contacts in the bi-metallic disc type heating sequencer to open which de-energizes the heater elements.

5.2 ELECTRONIC EXPANSION VALVE (EXV)

5.2.1 EXV OVERVIEW

The (-)HMVZ EcoNet™ enabled air handlers are equipped with an electronic refrigerant expansion device otherwise known as an EXV. One of the biggest advantages of an EXV is the control can intelligently change the EXV position based on system demands other than just suction line temperature. By the measurement of the suction pressure via the vapor line pressure transducer (factory installed) and the vapor line thermister (field connected to the vapor line, but factory provided within the air handler) the EcoNet™ enabled air handler control calculates the suction superheat at the indoor coil. This calculation permits the air handler control to make decisions for when to open and close the electronic expansion valve for the purpose of maintaining a predetermined suction superheat. The electronic valve is equipped with a 4-pole removable external stator,

and inlet and outlet Chatleff fittings for optimal serviceability. These valves also have an internal check valve to provide heat pump compatibility. When operating in heating mode, the air handler control will open the electronic valve completely to permit the check valve to operate and maximize reverse refrigerant flow.

5.3 VAPOR LINE TEMPERATURE SENSOR (THERMISTOR)

The indoor coil in (-)HMVZ air-handlers are equipped with a vapor line thermistor for the purpose of measuring the suction gas temperature during the cooling mode. The measured temperature is compared with the saturated suction temperature and used by the EcoNet™ Air-Handler Control Board to calculate the cooling mode suction superheat and adjust the electronic expansion valve (EXV) position to achieve the optimum cooling mode suction superheat level. The vapor line thermistor is attached to the vapor line with a clip outside the air-handler cabinet after the vapor line is brazed into the vapor line connection stub and then insulated with foam insulation provided in the parts bag included with the air-handler. The thermistor's wiring harness is connected to a mating connector on the EcoNet™ Air-Handler Control Board.

5.4 SUCTION PRESSURE TRANSDUCER

The indoor coil in (-)HMVZ air-handlers are equipped with a suction pressure transducer for the purpose of measuring the suction gas pressure during the cooling mode. The measured pressure is used by the EcoNet™ Air-Handler Control Board to calculate the cooling mode saturated suction temperature required to calculate the suction superheat level using the temperature measured at the vapor line thermistor and adjust the electronic expansion valve (EXV) position to achieve the optimum cooling mode suction superheat level. The suction pressure transducer is attached to a pressure port on the indoor coil suction header. The transducer's wiring harness is connected to a mating connector on the EcoNet™ Air-Handler Control Board.

5.5 THERMAL EXPANSION VALVE (TXV)

The indoor coil on (-)H2VZ/(-)H3VZ models are equipped with a conventional thermal expansion valve (TXV) for refrigerant control. The TXV's are non-bleed and have an internal check valve, making them compatible with AHRI matched 2-stage outdoor heat pumps.

5.6 BLOWER

The blower utilizes a forward curved centrifugal wheel. The blower housing is constructed from galvanized sheet metal. The motor is attached with a 4-arm belly band type mount that screws into the side of the blower housing. The control box attaches to the front of the blower housing for access through the blower access door. The blower slides into place on a track and is secured by 4 sheet metal screws.

5.7 TRANSFORMER

A 40VA transformer is located inside the control box attached to the blower housing which provides 24V control voltage for both the air-handler & the outdoor unit. The transformer in 208/240V models is wired from the factory for 240V applications, but has a separate 208V tap for 208V applications. The black wires connected to the 240V tap must be moved to the 208V tap when installing the air-handler in 208V applications to assure full 24V+ control voltage for reliable operation of the system controls.

5.8 INDOOR COIL ASSEMBLY

- The indoor coil slabs are a fin & tube design with enhanced aluminum fins & internally grooved aluminum tubing.
- Most models have 3 coil slabs in an "N" configuration, but some models have 2 coil slabs in an "A" configuration.
- All models have a self-draining polypropylene condensate drain pan to eliminate standing water & a painted & insulated sheet metal drip pan to catch any water drips from the coil when the air-handler is oriented in the horizontal position.
- All models have built-in sheet metal channels in various locations designed to manage condensate when the air-handler is oriented in the horizontal position, thus preventing water "blow-off".
- Copper stubs are provided for field tubing connections.
- The coil assembly slides into the air-handler on sheet metal rails. The coil is installed in the factory for upflow & horizontal left orientations. The coil must be removed and re-installed into the air-handler cabinet 180° from its factory orientation. An additional set of coil support rails must be installed before the coil can be re-installed. The additional set of rails are included with the air-handler for field installation.
- The Vapor Line Thermistor or TXV sensing bulb is shipped unattached & must be securely attached to the vapor line with the supplied clip or insulated with the supplied foam insulation.

6.0 ACCESSORIES & KITS

6.1 ELECTRIC RESISTANCE HEATER KITS

- All air-handlers are shipped without electric resistance heat.
- Electric heat kits ranging from 3kW to 30kW are available for field installation.
- Heater kit installation instructions are provided with the heater kit.
- All heater kits utilize open wire nickel chromium heating elements.
- An automatic reset over-temperature limit is provided to shut off the heater elements should air-flow become too restricted or if the blower motor fails.
- 13kW kits and larger are designed to operate in 2-stage heat mode if so desired or can be operated as single stage if the W1 & W2 thermostat pigtails are wired together.
- 208/240V single-phase (“J” Voltage) and 208/240V 3-phase (“C” Voltage) heater kits are available.
- 208/240V 3-phase (“C” Voltage) heater kits must be installed in “J” Voltage air-handlers since there are no “C” Voltage air-handlers available. “C” voltage heater kits are for 3-phase applications and allow for smaller wire & fuse/breaker size compared to single-phase “J” Voltage heater kits.
- The heater kit is controlled by the blower control based on thermostat inputs.
- All heater kits are available with a circuit breaker style disconnect.
- 10kW heater kits and smaller are also available with either a pull-out style disconnect or with no disconnect.
- Incoming electric power is connected directly to the heater kit power terminals.
- The heater kit is provided with 2 power wires that connect to the air-handler power terminal block, providing power to operate the blower motor and controls.
- The heater kit is also provided with a 4-pin connector that plugs into a mating plug on the blower control to allow the control of the heater based on thermostat inputs.

6.2 JUMPER BAR KITS

- **Jumper Bar Kit 3 Ckt. to 1 Ckt. RXBJ-A31** is used to convert single phase multiple three circuit units to a single supply circuit. Kit includes cover and screw for line side terminals.
- **Jumper Bar Kit 2 Ckt. to 1 Ckt. RXBJ-A21** is used to convert single phase multiple two circuit units to a single supply circuit. Kit includes cover and screw for line side terminals.

NOTE: No jumper bar kit is available to convert three phase multiple two circuit units to a single supply circuit.

6.3 AUXILIARY HORIZONTAL OVERFLOW PANS

Cabinet Size	Auxiliary Horizontal Overflow Pan Accessory Model Number
All 17.5" [44.5 cm] wide	RXBM-AC48
21" [53.3 cm] & 24.5" [62.2 cm] wide	RXBM-AC61

6.4 EXTERNAL FILTER BASES

Model Cabinet Size	Filter Size	Part Number	A	B
17	16" × 20" [40.6 cm × 50.8 cm]	RXHF-17	15.70	17.50
21	20" × 20" [50.8 cm × 50.8 cm]	RXHF-21	19.20	21.00
24	25" × 20" [63.5 cm × 50.8 cm]	RXHF-24	22.70	25.50

FIGURE 37
EXTERNAL FILTER BASE: RXHF-

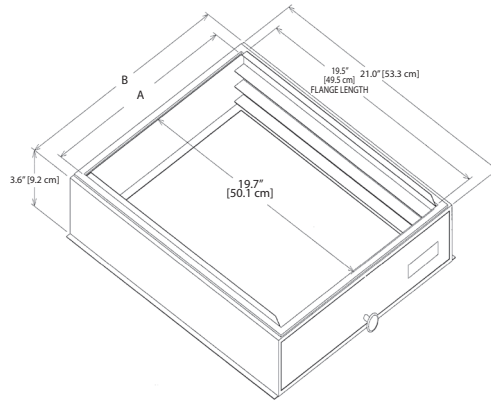

6.5 COMBUSTIBLE FLOOR BASES

For high heat downflow applications. (See Section 3.2.2.)

Model Cabinet Size	Combustible Floor Base Model Number
17	RXHB-17
21	RXHB-21
24	RXHB-24

6.6 HORIZONTAL ADAPTER KITS

This horizontal adapter kit is used to convert RCHZ replacement coils for horizontal applications if water management parts from original coil are not usable or are unavailable. See the following table to order proper horizontal adapter kit.

REPLACEMENT R-410A UNCASED AIR HANDLER COIL	HORIZONTAL ADAPTER KIT MODEL NUMBER
RCHZ2417STANVU	RXHH-A02
RCHZ2417MTANVU	RXHH-A03
RCHZ3617STANVU	RXHH-A03
RCHZ3621MTAAVU	RXHH-A06
RCHZ3621MTANVU	RXHH-A04
RCHZ3621STANVU	RXHH-A03
RCHZ3721MTANVU	RXHH-A04
RCHZ4821STAAVU	RXHH-A06
RCHZ4821STANVU	RXHH-A04
RCHZ4824STANVU	RXHH-A04
RCHZ4924STANVU	RXHH-A05
RCHZ6021STAAVU	RXHH-A06
RCHZ6024STANVU	RXHH-A05
RCHZ2517STANVU	RXHH-A02
RCHZ3717STANVU	RXHH-A03
RCHZ4921STANVU	RXHH-A04
RCHZ6124STANVU	RXHH-A05
RCHZ2417SEANVU	RXHH-A02
RCHZ2421HEANVU	RXHH-A04
RCHZ2421MEANVU	RXHH-A03
RCHZ2421HEAAVU	RXHH-A06
RCHZ6021SEAAVU	RXHH-A06
RCHZ6024SEANVU	RXHH-A05

6.7 SUPPLY AND RETURN AIR TEMPERATURE SENSOR KIT

RXHT-A02

7.0 MAINTENANCE

For continuing high performance, and to minimize possible equipment failure, it is essential that periodic maintenance be performed on this equipment. Consult your local dealer as to the proper frequency of maintenance and the availability of a maintenance contract.

IMPORTANT: Before performing any service or maintenance procedures, see the "Safety Information" (Section 1.0) at the front of this manual.

7.1 AIR FILTER

Check the system filter every ninety days or as often as found to be necessary and if obstructed, clean or replace at once.

WARNING

Units with circuit breaker(s) meet requirements as a service disconnect switch, however, if access is required to the line side (covered) of the circuit breaker, this side of the breaker(s) will be energized with the breaker(s) de-energized. Contact with the line side can cause electrical shock resulting in personal injury or death.

A qualified installer, service agency or HVAC professional should instruct the homeowner on how to access filters for regular maintenance.

IMPORTANT: Do not operate the system without a filter in place.

- New filters are available from a local distributor or home supply retailer.

7.2 INDOOR COIL, DRAIN PAN, DRAIN LINE

Inspect the indoor coil, drain pan, and drain line once each year for cleanliness and clean as necessary. Be sure to check the finned surface on the return side of the coil. It may be necessary to remove the air-filter and use a mirror and flashlight to view the return side of the coil.

NOTE: A proper filter is the best defense against a dirty coil. Regardless of the filter choice, proper air flow and velocity also play a crucial role in how effective a filter will be. Most filters will lose their effectiveness when face velocities exceed 300 - 400 feet per minute [1.5 - 2.0 m/s]. Excessive air velocity can allow particles to pass right through the media. Additionally, loaded or restrictive filters may lose their shape in higher air velocity applications and allow unfiltered air to bypass the filter altogether around the sides.

IMPORTANT: Coil and Drainpan Cleaning Method

Clean the finned surface of the indoor coil by rinsing the coil from both sides with clean warm water and/or with a vacuum with a soft brush attachment to remove accumulated contaminants and lint. It is important not to allow the tool to damage or bend the fins. Many chemical cleaners will attack the aluminum tubes which can cause refrigerant leaks. Therefore, use only clean warm water for cleaning aluminum tube evaporator coils. Do not use caustic household drain cleaners or bleach in the condensate pan or near the indoor coil as they will damage the aluminum fins and tubes.

7.3 BLOWER MOTOR AND WHEEL

Inspect the blower motor and wheel for cleanliness. It should be several years before it would become necessary to clean the blower motor and wheel.

- If it becomes necessary to remove the blower assembly from the unit, see instructions on removal and replacement of motor, blower, and blower wheel in Sections 7.5-7.7 below.
- The blower motor and wheel may be cleaned by using a vacuum with a soft brush attachment. Remove grease with a mild solvent such as hot water and detergent. Be careful not to disturb the balance weights (clips) on the blower wheel blades. Do not drop or bend wheel as balance will be affected.

7.4 MOTOR LUBRICATION

The blower motor sleeve bearings are pre-lubricated by the motor manufacturer and do not have oiling ports. Motor should operate for an indefinite period of time without additional lubrication.

7.5 BLOWER ASSEMBLY REMOVAL & REPLACEMENT

Removing the blower assembly is not normally required for normal service and maintenance. Removal is necessary for replacement of defective parts such as motor, blower wheel. After extended use, removal of the blower assembly may become necessary for

a thorough cleaning of the blower motor and wheel.

1. Mark field power supply wiring (for replacement) attached to terminal block or circuit breaker(s) on blower assembly. Remove wiring from terminal block or circuit breaker(s).

⚠ WARNING

If removal of the blower assembly is required, all disconnect switches supplying power to the equipment must be de-energized and locked (if not in sight of unit) so the field power wires can be safely removed from the blower assembly. Failure to do so can cause electrical shock resulting in personal injury or death.

2. Mark low voltage control wiring (for replacement) where attached to unit control board. Remove thermostat wiring from control board.
3. Remove 4 screws holding blower assembly to front channel of cabinet and pull blower assembly from cabinet.
4. To replace blower assembly, slide blower assembly into blower deck. Make sure blower assembly engages lances in deck properly. If assembly hangs up, check to make sure top and bottom are lined up in proper locations.
5. Slide blower assembly to back of cabinet and make sure it is completely engaged.
6. Replace 4 screws holding blower assembly to front channel of cabinet. Take care not to strip screws.
7. Replace low voltage control wiring and make sure wiring is per the wiring diagram and all connections are tight and secure.
8. Replace field power wiring to terminal block or circuit breaker(s) on control area of blower assembly. Make sure wires are connected per the wiring diagram. Tighten supply power wiring securely to terminals lugs.
9. Make sure wiring is within cabinet and will not interfere with access door. Make sure there is proper separation between low voltage control wiring and field power wiring.
10. Replace blower assembly control access panel before energizing equipment.

FIGURE 38
INTERNAL MOTOR PLUG AND SOCKET

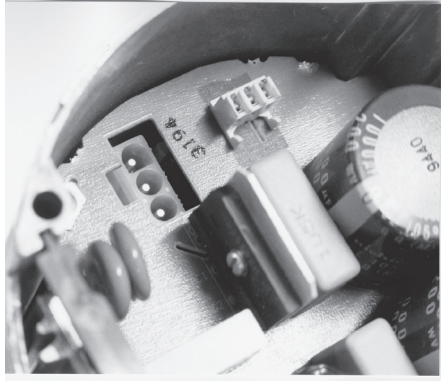

7.6 MOTOR REPLACEMENT

With the blower assembly removed, the indoor blower motor can be removed and replaced using the following procedure:

1. Remove motor leads from the motor high and low voltage plugs. Note the lead locations for ease of re-assembly.
2. Loosen the set screw holding the blower wheel onto the motor shaft. The shaft extends through the blower hub so that a wrench can be used on the extended shaft to break the shaft loose if necessary. Be careful not to damage the shaft. Use a wheel puller on the groove in the hub if necessary.
3. Loosen the bolt holding the wire motor band around the motor shell and pull the motor from the motor mount. Note the motor position in the mount for re-assembly.
4. To re-assemble, insert the motor shaft through the hub in the blower wheel and orient the motor to original position.

FIGURE 39
ECM MOTOR COMPONENTS

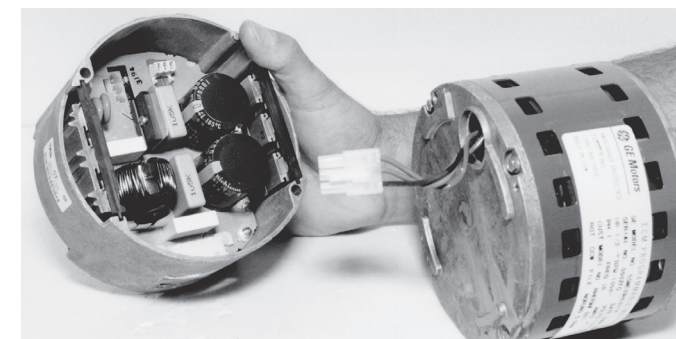
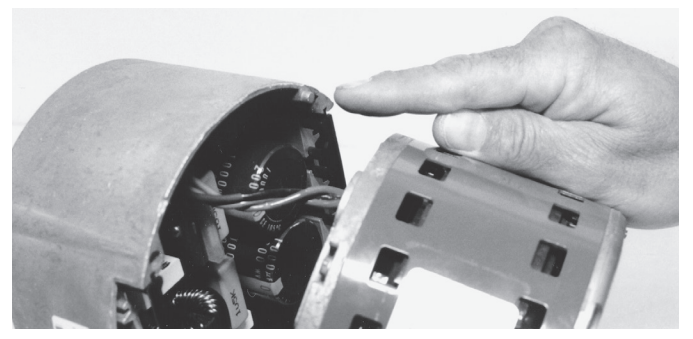

FIGURE 40
MOTOR ALIGNMENT PIN



5. For proper motor cooling, it is important that the motor be mounted the same as the original, as far into the blower as practical.
6. The dimension from the face of the motor end plate (shaft end) to the edge of the motor mount belly band should be:

DIMENSION	TONNAGE	CABINET SIZE
1 ³ / ₃₂ " [2.8 cm]	2 - 3	17
1 ¹ / ₂ " [3.8 cm]	2 - 5	21
2 ⁷ / ₈ " [7.3 cm]	5	24

7. With motor held to above position and motor lead plugs oriented to the original position (the wire connectors on the motor must point straight to the front of the unit. Securely tighten the bolt on the mount band to the motor shell.
8. Turn the motor shaft so that the flat on the shaft is located under blower wheel setscrew, and the blower wheel is centered in the blower housing with the same distance on each side between the inlet venturi and the outside of the blower wheel.
9. Re-assemble the motor wiring (high and low voltage plugs) into the motor.

IMPORTANT: DO NOT FORCE POWER PLUG INTO THE MOTOR CONNECTOR BACKWARDS. The A.C. power plug to the motor has locking tabs. It has been proven that by applying excessive force to the A.C. cable half of the connector it is possible to force the connector in backwards. It will not seat and “click” properly but will make connection. If A.C. power is applied with the connector reversed the motor will be immediately destroyed.

7.7 MOTOR CONTROL MODULE REPLACEMENT

The control module on ECM motors is field serviceable. The motor can be replaced or the motor control can be replaced.

7.8 BLOWER WHEEL REPLACEMENT

With the blower assembly removed and the motor assembly removed (see above instructions), remove the screws holding the blower wrap (cutoff) to the blower sides.

1. With wrap (cutoff) screws removed, cut off end of blower wrap will spring up. Lifting wrap blower wheel is removed through the discharge opening in the blower housing.
2. To replace, make sure wheel is oriented properly with hub to the opposite side from the motor. Lift blower wrap and insert blower wheel through discharge opening in the blower housing.
3. Hold blower wrap down into position and replace screws holding blower wrap to blower sides.
4. See motor replacement and blower assembly instructions for remaining assembly procedure.

7.9 ECONET™ AIR HANDLER CONTROL BOARD REPLACEMENT

Verification of the *EcoNet™ Air Handler* control board failure is required before replacement. Access the diagnostic codes using a service tool or access the service menus using the control center (the system must be wired as a serial communicating system to access the service and installer menus using the thermostat). Reference the EcoNet™ Air Handler Control Board Diagnostic Code Table (Table 5) in Section 8.2.

⚠ WARNING

Disconnect all power to unit before installing or servicing. More than one disconnect switch may be required to de-energize the equipment. Hazardous voltage can cause severe personal injury or death.

FIGURE 41
ECONET™ AIR HANDLER BOARD REPLACEMENT

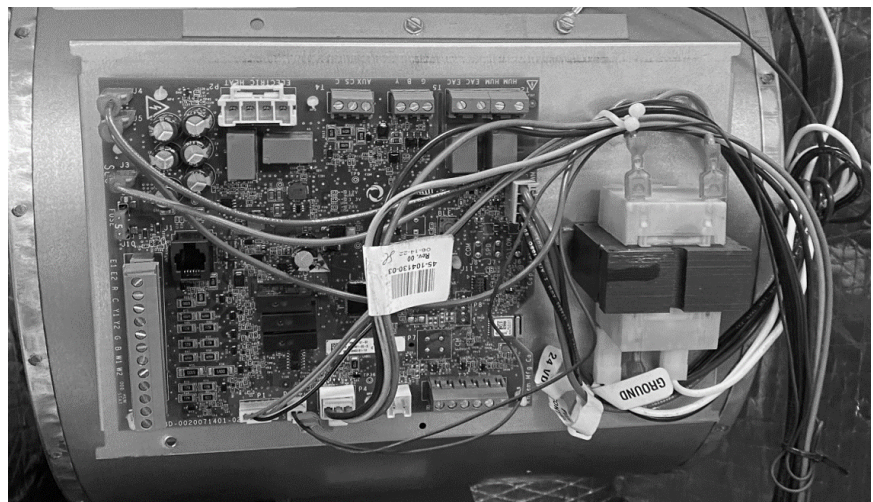

7.10 REPLACEMENT PARTS

Any replacement part used to replace parts originally supplied on equipment must be the same as or an approved alternate to the original part supplied. The manufacturer will not be responsible for replacement parts not designed to physically fit or operate within the design parameters the original parts were selected for.

These parts include but are not limited to: Circuit breakers, heater controls, heater limit controls, heater elements, motor, motor capacitor, blower control, control transformer, blower wheel, indoor coil and sheet metal parts.

When ordering replacement parts, it is necessary to order by part number and include with the order the complete model number and serial number from the unit data plate. (See Parts List for unit component part numbers).

8.0 DIAGNOSTICS

8.1 GENERAL DIAGNOSTICS

Problem	Possible Cause (Suggested Fix)
Blower Motor will not operate	<ul style="list-style-type: none">Failed motor (replace)Failed motor control module (replace module)Blown 5A fuse on blower control (check for control circuit short, replace fuse)Loose wiring connection or broken wire (check connections & wiring)Failed transformer (replace)Failed blower control (replace)Disconnect breaker is turned off or has tripped due to over-current or shorted circuit (check for shorts, reset breaker)
Excessive vibration	<ul style="list-style-type: none">Blower wheel out of balance (replace or clean blower wheel)
Water overflowing drain pan	<ul style="list-style-type: none">Plugged drain (clear drain)Unit not level (level unit)
Electric heater not heating properly or not heating at all, but blower motor is operating	<ul style="list-style-type: none">Over temperature limit has tripped (check for low airflow)Over temperature limit has failed (replace)Sequencer or contactor has failed (replace)One or more heating elements have burned out (replace)
Coil is frozen up	<ul style="list-style-type: none">System low on refrigerant charge (check for leaks & adjust charge)Dirty return air filter (replace filter)Inadequate airflow due to incorrect blower motor speed selected (select higher speed) or excessively restrictive duct system (correct duct system)
Excessive airflow	<ul style="list-style-type: none">Incorrect blower motor speed selected (select lower speed)
Water blow-off from coil	<ul style="list-style-type: none">Excessive airflow (select lower blower motor speed)Contaminants on coil fins (clean coil)Damaged coil fins (comb out fins or replace coil)
TXV not controlling properly	<ul style="list-style-type: none">TXV bulb or vapor line thermistor not positioned correctly or clamp not tight (check position of TXV sensing bulb or vapor line thermistor and tightness of clamp)Failed TXV or EXV (replace)Plugged TXV or EXV inlet screen (clean or replace screen or replace TXV or EXV)Bad Electrical connection to suction pressure transducer (check wiring connections)Failed suction pressure transducer (replace transducer)Bad electrical connection to EXV control (check wiring connections)Failed EXV control (replace control)

8.2 ECONET™ AIR-HANDLER CONTROL BOARD DIAGNOSTIC CODES

TABLE 5

ECONET™ AIR HANDLER DIAGNOSTIC CODES

LED FLASH CODE	FAULT MESSAGE	ALARM	Status/Possible Cause - Troubleshooting Information
2	BLOWER RPM FEEDBACK MISSING	A100_F DETECT RPM MOTOR FAILURE	<ul style="list-style-type: none"> • Make sure the ECM motor wiring harness is plugged into the ECM motor and control board • TEST the ECM for proper operation
3	EVAP. TEMP. SENSOR FAILED	T085_F EVAP TEMP THERMISTOR FAILURE	<ul style="list-style-type: none"> • Make sure the sensor is plugged into the air handler control board • Check the resistance of the sensor. Replace if it is out of range
4	SUCTION TEMP. SENSOR FAILED	A113_A SUCTION LINE THERMISTOR FAILURE	<ul style="list-style-type: none"> • Make sure the sensor is plugged into the air handler control board • Check the resistance of the sensor. Replace if it is out of range
5	SUCTION PRESSURE TRANSDUCER FAILED	T086_F SUCTION PRESSURE SENSOR FAILURE	<ul style="list-style-type: none"> • Make sure the transducer is plugged into the air handler control board • If operating in heating mode, this flash code is normal
6	WATER INLET TEMP SENSOR FAILED	A112_A WATER INLET THERMISTOR FAILURE	<ul style="list-style-type: none"> • Make sure the sensor is plugged into the air handler control board • Check the resistance of the sensor. Replace if it is out of range
7	RETURN AIR TEMP SENSOR FAILED	T081_F RETURN AIR SENSOR FAULT	<ul style="list-style-type: none"> • Make sure the sensor is plugged into the air handler control board • Check the resistance of the sensor. Replace if it is out of range
8	SUPPLY AIR TEMP SENSOR FAILED	T082_F SUPPLY AIR SENSOR FAULT	<ul style="list-style-type: none"> • Make sure the sensor is plugged into the air handler control board • Check the resistance of the sensor. Replace if it is out of range
9	INTERNAL CONTROL FAULT	A093_F CONFIGURATION DATA RESTORE FAILURE	<ul style="list-style-type: none"> • Check for proper system operation • Replace Control

NOTE: If multiple status codes are active concurrently, the highest priority status code is displayed (the highest priority is actually the lowest blink rate). If a status code is flashing and a new one of higher priority occurs the new status code will flash. The flash codes will repeat continuously until cleared or overridden by a higher priority code. The operational code information is also passed to the user interface when requested.

9.0 WIRING DIAGRAMS

9.1 WIRING DIAGRAM

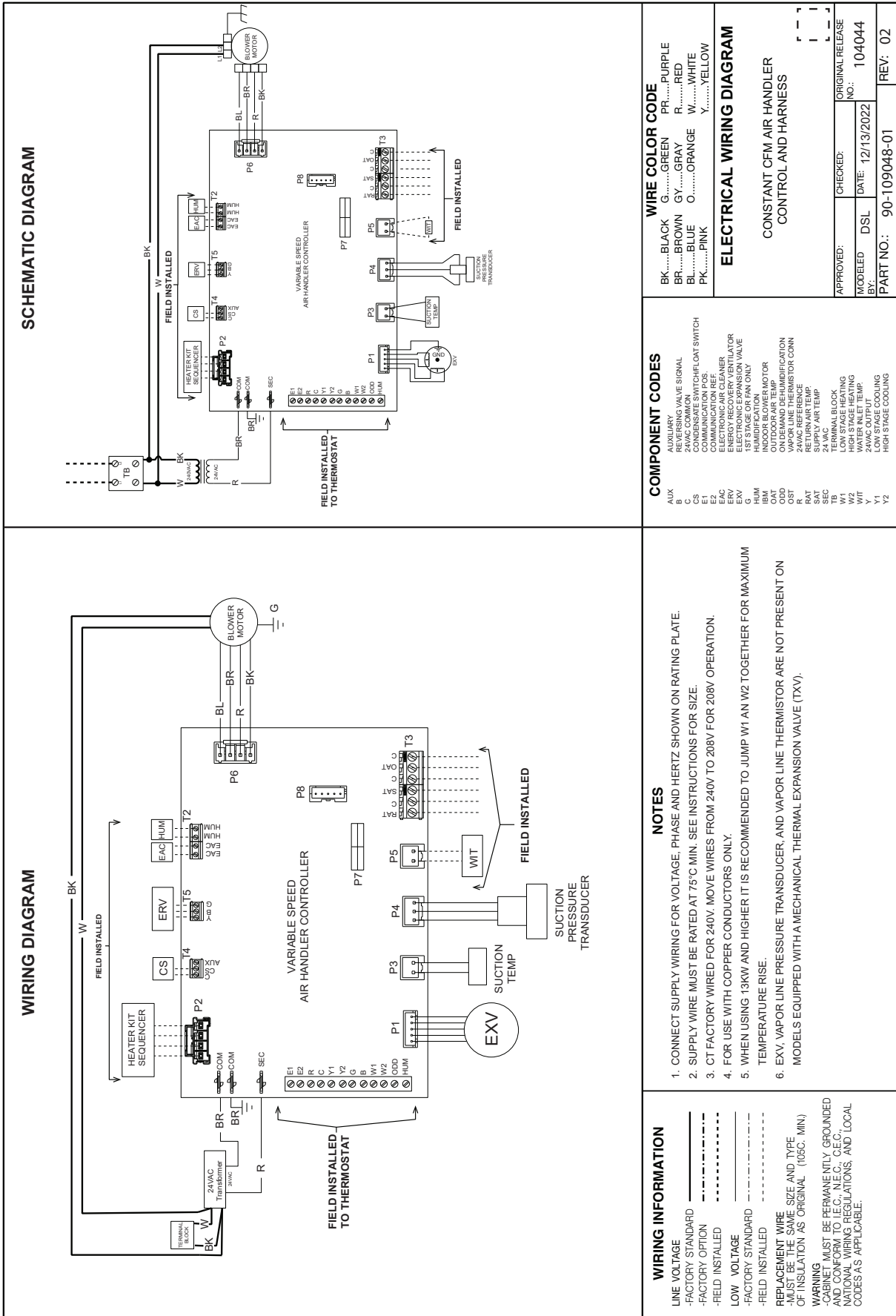

SCHEMATIC DIAGRAM

WIRING DIAGRAM

WIRE COLOR CODE

BK.....BLACK	G.....GREEN	PR.....PURPLE
BR.....BROWN	GY.....GRAY	R.....RED
BL.....BLUE	O.....ORANGE	W.....WHITE
PK.....PINK	Y.....YELLOW	

ELECTRICAL WIRING DIAGRAM

CONSTANT CFM AIR HANDLER CONTROL AND HARNESS

APPROVED:	CHECKED:	ORIGINAL RELEASE
MODELED	DATE: 12/13/2022	NO.: 104044
BY: DSL		
PART NO.: 90-109048-01		REV: 02

COMPONENT CODES

AUX	REVERSING VALVE SIGNAL
B	24VAC COMMON
C	CONDENSATE SWITCH/FLOAT SWITCH
CS	COMMUNICATION REF.
E2	COMMUNICATION REF.
EAC	ELECTRONIC AIR CLEANER
ERV	ENERGY RECOVERY VENTILATOR
G	1ST STAGE OR FAN ONLY
HUM	HUMIDIFICATION
HUM	HUMIDIFIER MOTOR
ODD	ON DEMAND DEHUMIDIFICATION
OST	VAPOR LINE THERMISTOR CONN
RAT	RETURN AIR TEMP.
SAT	SUPPLY AIR TEMP.
SEC	24 VAC
W1	WATER THERMISTOR
W2	LOW STAGE HEATING
WIT	WATER INLET TEMP.
Y1	24VAC OUTPUT
Y2	HIGH STAGE COOLING

- NOTES**
1. CONNECT SUPPLY WIRING FOR VOLTAGE, PHASE AND HERTZ SHOWN ON RATING PLATE.
 2. SUPPLY WIRE MUST BE RATED AT 75°C MIN. SEE INSTRUCTIONS FOR SIZE.
 3. CT FACTORY WIRED FOR 240V. MOVE WIRES FROM 240V TO 208V FOR 208V OPERATION.
 4. FOR USE WITH COPPER CONDUCTORS ONLY.
 5. WHEN USING 13KW AND HIGHER IT IS RECOMMENDED TO JUMP W1 AN W2 TOGETHER FOR MAXIMUM TEMPERATURE RISE.
 6. EXV, VAPOR LINE PRESSURE TRANSDUCER, AND VAPOR LINE THERMISTOR ARE NOT PRESENT ON MODELS EQUIPPED WITH A MECHANICAL THERMAL EXPANSION VALVE (TXV).

WIRING INFORMATION

LINE VOLTAGE _____

-FACTORY STANDARD _____

-FACTORY OPTION _____

-FIELD INSTALLED _____

LOW VOLTAGE _____

-FACTORY STANDARD _____

-FIELD INSTALLED _____

REPLACEMENT WIRE _____

-MUST BE THE SAME SIZE AND TYPE _____

OF INSULATION AS ORIGINAL (105C. MIN.)

WARNING

-CABINET MUST BE PERMANENTLY GROUNDED AND CONFORM TO I.E.C., N.E.C., C.E.C., NATIONAL WIRING REGULATIONS, AND LOCAL CODES AS APPLICABLE.